

- GB** Fitting instructions
D Montageanleitung
F Instructions de montage
NL Montage-instructies
I Istruzioni per il montaggio
E Instrucciones de montaje
PT Instruções de Montagem
S Monteringsanvisning
FIN Asennusohje
EST Paigaldusjuhend
LAT Stiprināšanas instrukcija
LIT Pritvirtinimo instrukcijos
PL Instrukcja montażu
RU Инструкции по установке
CZ Návod na montáž
SK Návod na montáž
SLO Navodila za pritrjevanje
HR Uputa za sastavljanje
HU A felszerelés módja
GR Οδηγίες συναρμολόγησης
TR Montaj talimatları
中文 安装说明
日本語 取扱(取付)説明書
한국어 장착 지침
ไทย คำแนะนำการติดตั้ง

Mitsubishi-Volvo

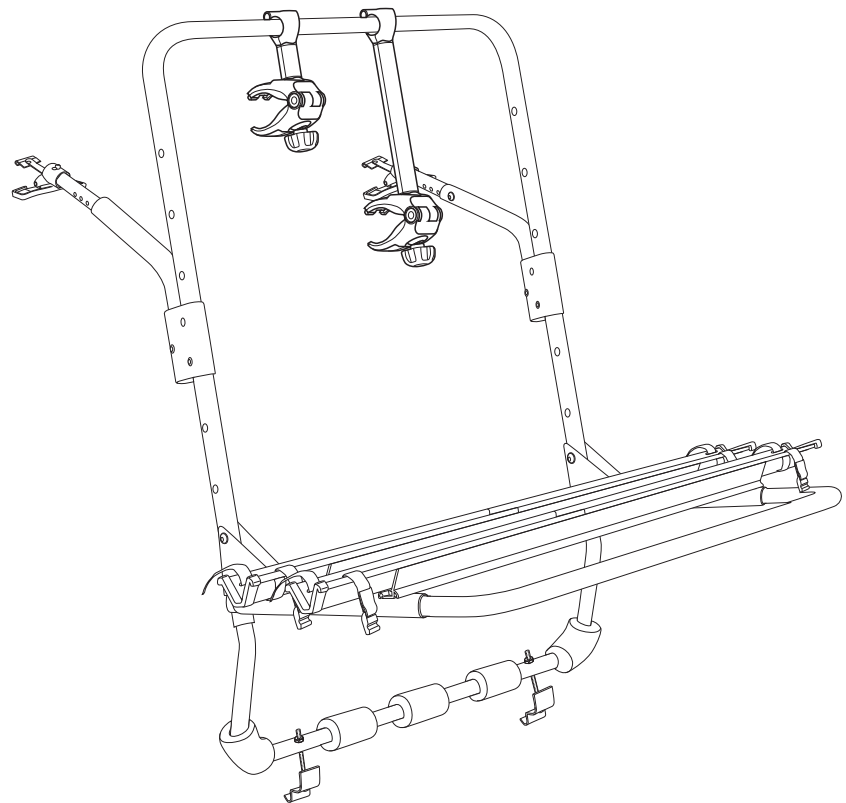

Model	Max.
▲ MITSUBISHI Space Gear, 5-dr MPV, 95-	3
▲ MITSUBISHI Space Wagon, 5-dr MPV, 99-03	4
▲ NISSAN Primera (W11), 5-dr Estate, 97-01	3
▲ NISSAN Terrano (WD21), 3/5-dr SUV, 88-96	3
▲ OPEL Omega, 5-dr Estate, 94-03	3
▲ OPEL Sintra, 5-dr MPV, 96-99	3
▲ OPEL Vectra, 5-dr Estate, 03-05	3
▲ OPEL Zafira, 5-dr MPV, 98-02	3
▲ OPEL Zafira, 5-dr MPV, 03-04	3
▲ OPEL Zafira, 5-dr MPV, 05-	3
▲ PEUGEOT 405, 5-dr Estate, 89-97	3
▲ PEUGEOT 806, 5-dr MPV, 94-02	2
▲ SEAT Alhambra, 5-dr MPV, 96-00	3
▲ SEAT Alhambra, 5-dr MPV, 01-	3
▲ SUBARU Legacy, 5-dr Estate, 89-93	3
▲ SUBARU Legacy, 5-dr Estate, 94-02	3
▲ TOYOTA Avensis, 5-dr Estate, 98-02	3
▲ TOYOTA Avensis Verso, 5-dr MPV, 01-03	3
▲ TOYOTA Carina E, 5-dr Estate, 94-97	3
▲ TOYOTA Picnic, 5-dr MPV, 97-00	4
▲ TOYOTA Picnic, 5-dr MPV, 01-	4
▲ VOLKSWAGEN Golf III, 5-dr Variant, 94-98	3
▲ VOLKSWAGEN Golf III, 3/5-dr Hatchback, 92-97	3
▲ VOLKSWAGEN Passat, 5-dr Variant, 88-97	4
▲ VOLKSWAGEN Sharan, 5-dr MPV, 96-00	3
▲ VOLKSWAGEN Sharan, 5-dr MPV, 01-	3
VOLVO V50, 5-dr Estate, 04-	3
VOLVO V70, 5-dr Estate, 00-03	2
VOLVO V70, 5-dr Estate, 04-07	2



973-16

973160



MITSUBISHI Space Gear, 5-dr MPV, 95-	4
MITSUBISHI Space Wagon, 5-dr MPV, 99-03	3
NISSAN Primera (W11), 5-dr Estate, 97-01	2
NISSAN Terrano (WD21), 3/5-dr SUV, 88-96	2
OPEL Omega, 5-dr Estate, 94-03	2
OPEL Sintra, 5-dr MPV, 96-99	4
OPEL Vectra, 5-dr Estate, 03-05	2
OPEL Zafira, 5-dr MPV, 98-02	4
OPEL Zafira, 5-dr MPV, 03-04	4
OPEL Zafira, 5-dr MPV, 05-	3
PEUGEOT 405, 5-dr Estate, 89-97	1
PEUGEOT 806, 5-dr MPV, 94-02	2
SEAT Alhambra, 5-dr MPV, 96-00	3

SEAT Alhambra, 5-dr MPV, 01-	3
SUBARU Legacy, 5-dr Estate, 89-93	2
SUBARU Legacy, 5-dr Estate, 94-02	2
TOYOTA Avensis, 5-dr Estate, 98-02	2
TOYOTA Avensis Verso, 5-dr MPV, 01-03	3
TOYOTA Carina E, 5-dr Estate, 94-97	2
TOYOTA Picnic, 5-dr MPV, 97-00	2
TOYOTA Picnic, 5-dr MPV, 01-	2
VOLKSWAGEN Golf III, 5-dr Variant, 94-98	2
VOLKSWAGEN Golf III, 3/5-dr Hatchback, 92-97	1
VOLKSWAGEN Passat, 5-dr Variant, 88-97	1
VOLKSWAGEN Sharan, 5-dr MPV, 96-00	3
VOLKSWAGEN Sharan, 5-dr MPV, 01-	3
VOLVO V50, 5-dr Estate, 04-	2
VOLVO V70, 5-dr Estate, 00-03	2
VOLVO V70, 5-dr Estate, 04-07	2

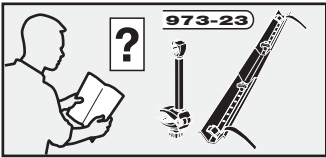
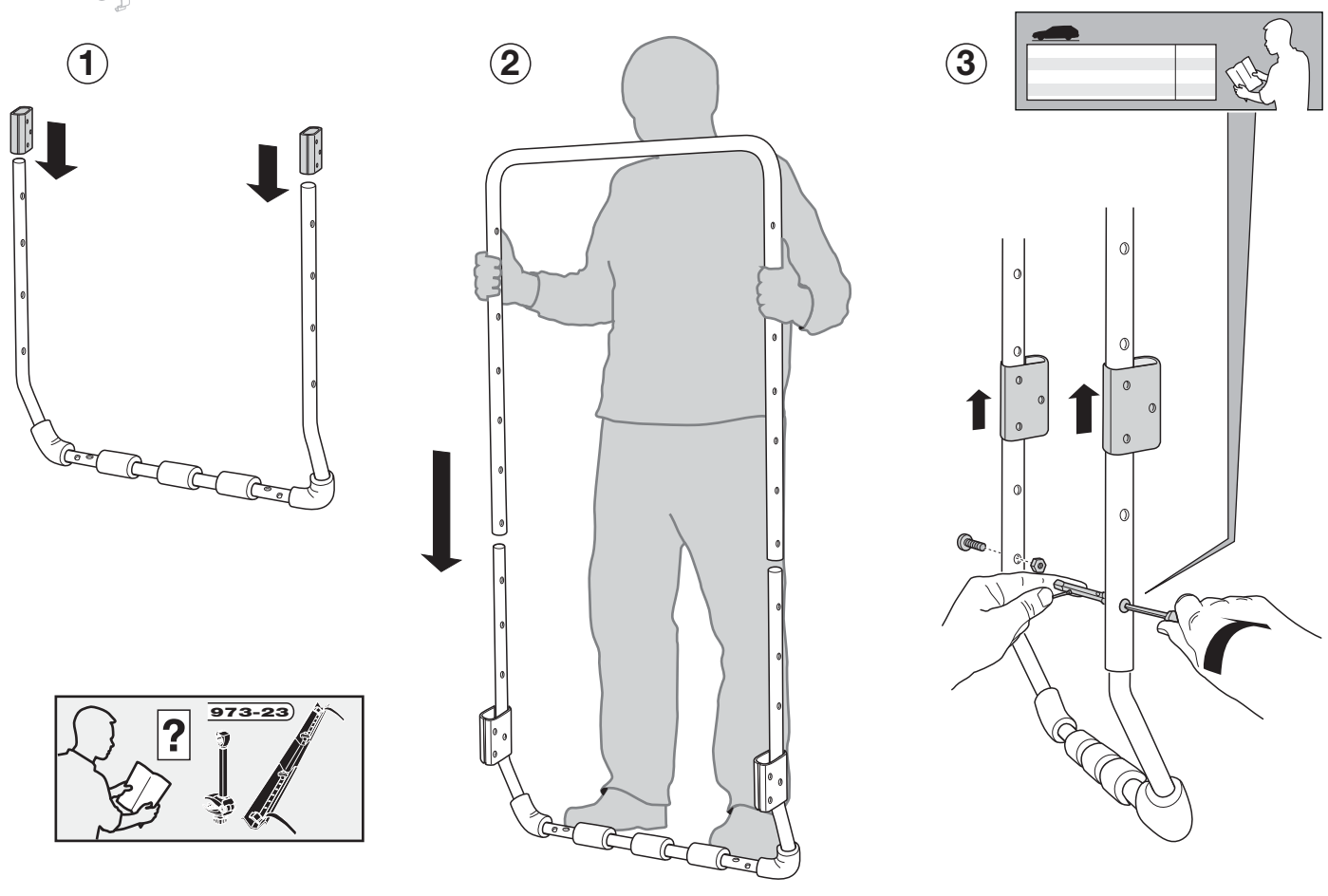
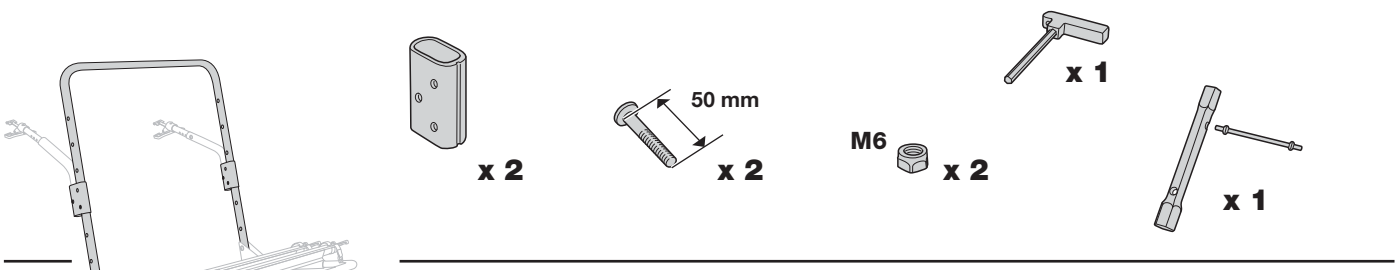
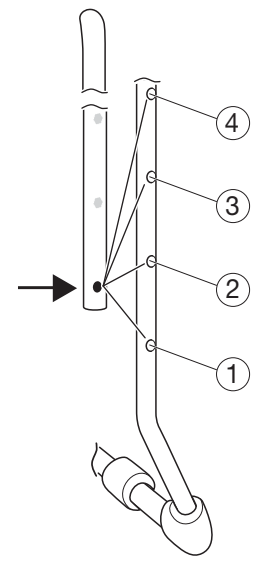

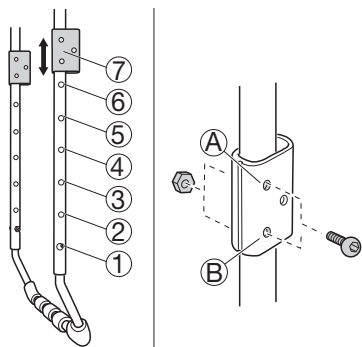

MITSUBISHI Space Gear , 5-dr MPV, 95-	5	A
MITSUBISHI Space Wagon , 5-dr MPV, 99-03	4	A
NISSAN Primera (W11) , 5-dr Estate, 97-01	4	A
NISSAN Terrano (WD21) , 3/5-dr SUV, 88-96	3	B
OPEL Omega , 5-dr Estate, 94-03	4	A
OPEL Sintra , 5-dr MPV, 96-99	4	A
OPEL Vectra , 5-dr Estate, 03-05	3	B
OPEL Zafira , 5-dr MPV, 98-02	3	A
OPEL Zafira , 5-dr MPV, 03-04	3	A
OPEL Zafira , 5-dr MPV, 05-	3	B

PEUGEOT 405 , 5-dr Estate, 89-97	6	A
PEUGEOT 806 , 5-dr MPV, 94-02	6	A
SEAT Alhambra , 5-dr MPV, 96-00	4	B
SEAT Alhambra , 5-dr MPV, 01-	4	B
SUBARU Legacy , 5-dr Estate, 89-93	3	B
SUBARU Legacy , 5-dr Estate, 94-02	4	A
TOYOTA Avensis , 5-dr Estate, 98-02	4	A
TOYOTA Avensis Verso , 5-dr MPV, 01-03	3	A
TOYOTA Carina E , 5-dr Estate, 94-97	3	B
TOYOTA Picnic , 5-dr MPV, 97-00	4	A
TOYOTA Picnic , 5-dr MPV, 01-	4	A
VOLKSWAGEN Golf III , 5-dr Variant, 94-98	4	A
VOLKSWAGEN Golf III , 3/5-dr Hatchback, 92-97	3	B
VOLKSWAGEN Passat , 5-dr Variant, 88-97	4	B
VOLKSWAGEN Sharan , 5-dr MPV, 96-00	4	B
VOLKSWAGEN Sharan , 5-dr MPV, 01-	4	B
VOLVO V50 , 5-dr Estate, 04-	2	A
VOLVO V70 , 5-dr Estate, 00-03	3	A
VOLVO V70 , 5-dr Estate, 04-07	3	A

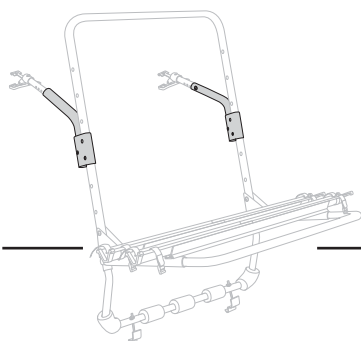

x 2

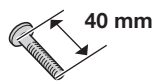

x 2

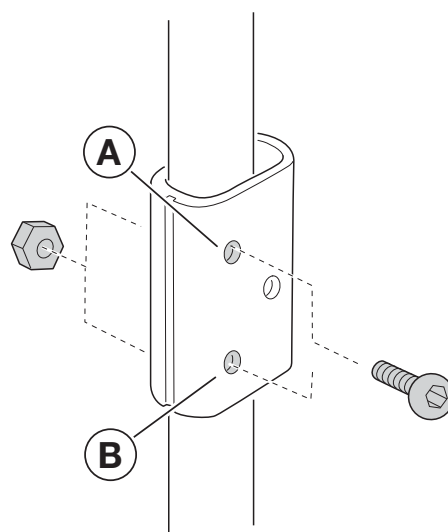
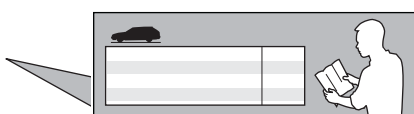
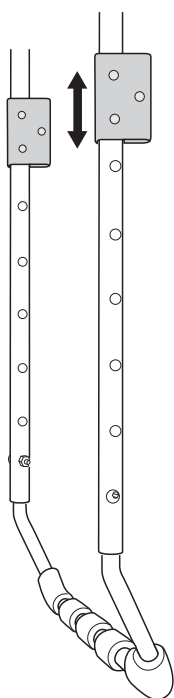

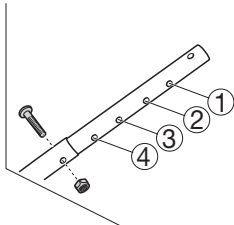
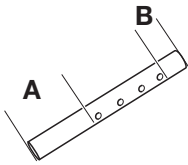

MITSUBISHI Space Gear , 5-dr MPV, 95-	B	1
MITSUBISHI Space Wagon , 5-dr MPV, 99-03	B	2
NISSAN Primera (W11) , 5-dr Estate, 97-01	A	4
NISSAN Terrano (WD21) , 3/5-dr SUV, 88-96	B	6
OPEL Omega , 5-dr Estate, 94-03	B	4
OPEL Sintra , 5-dr MPV, 96-99	B	2
OPEL Vectra , 5-dr Estate, 03-05	B	5
OPEL Zafira , 5-dr MPV, 98-02	A	6
OPEL Zafira , 5-dr MPV, 03-04	A	6
OPEL Zafira , 5-dr MPV, 05-	B	6
PEUGEOT 405 , 5-dr Estate, 89-97	A	3
PEUGEOT 806 , 5-dr MPV, 94-02	B	1

SEAT Alhambra , 5-dr MPV, 96-00	B	5
SEAT Alhambra , 5-dr MPV, 01-	B	5
SUBARU Legacy , 5-dr Estate, 89-93	B	5
SUBARU Legacy , 5-dr Estate, 94-02	A	6
TOYOTA Avensis , 5-dr Estate, 98-02	A	7
TOYOTA Avensis Verso , 5-dr MPV, 01-03	A	7
TOYOTA Carina E , 5-dr Estate, 94-97	B	6
TOYOTA Picnic , 5-dr MPV, 97-00	B	3
TOYOTA Picnic , 5-dr MPV, 01-	B	3
VOLKSWAGEN Golf III , 5-dr Variant, 94-98	B	3
VOLKSWAGEN Golf III , 3/5-dr Hatchback, 92-97	A	5
VOLKSWAGEN Passat , 5-dr Variant, 88-97	B	3
VOLKSWAGEN Sharan , 5-dr MPV, 96-00	B	5
VOLKSWAGEN Sharan , 5-dr MPV, 01-	B	5
VOLVO V50 , 5-dr Estate, 04-	B	5
VOLVO V70 , 5-dr Estate, 00-03	B	1
VOLVO V70 , 5-dr Estate, 04-07	B	1

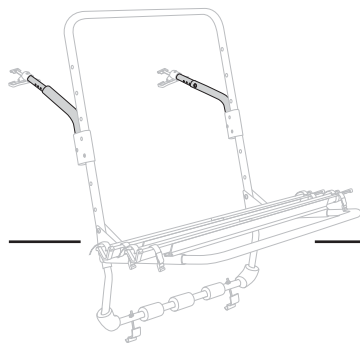

x 2

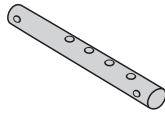

x 2



x 4

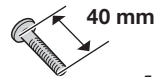

x 4

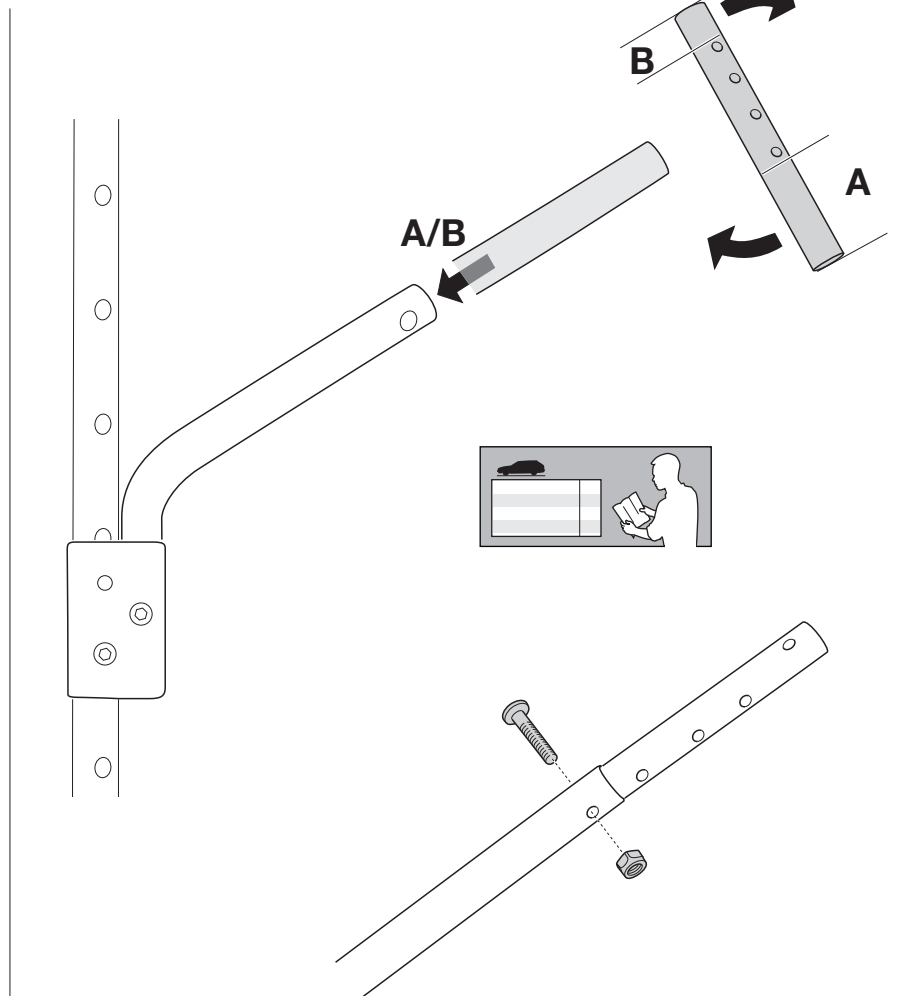
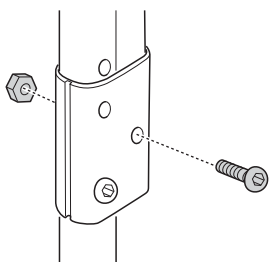
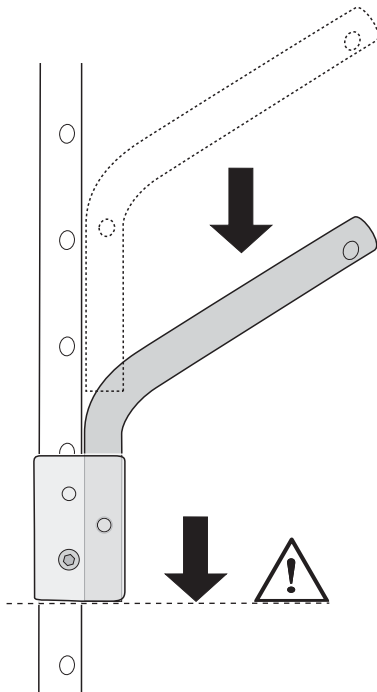

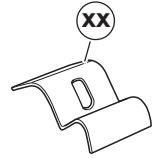
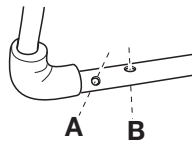

MITSUBISHI Space Gear , 5-dr MPV, 95-	A
MITSUBISHI Space Wagon , 5-dr MPV, 99-03	A
NISSAN Primera (W11) , 5-dr Estate, 97-01	A
NISSAN Terrano (WD21) , 3/5-dr SUV, 88-96	A
OPEL Omega , 5-dr Estate, 94-03	A
OPEL Sintra , 5-dr MPV, 96-99	A
OPEL Vectra , 5-dr Estate, 03-05	B
OPEL Zafira , 5-dr MPV, 98-02	A
OPEL Zafira , 5-dr MPV, 03-04	A
OPEL Zafira , 5-dr MPV, 05-	B
PEUGEOT 405 , 5-dr Estate, 89-97	A
PEUGEOT 806 , 5-dr MPV, 94-02	A
SEAT Alhambra , 5-dr MPV, 96-00	B
SEAT Alhambra , 5-dr MPV, 01-	B
SUBARU Legacy , 5-dr Estate, 89-93	A
SUBARU Legacy , 5-dr Estate, 94-02	A
TOYOTA Avensis , 5-dr Estate, 98-02	A
TOYOTA Avensis Verso , 5-dr MPV, 01-03	B
TOYOTA Carina E , 5-dr Estate, 94-97	A
TOYOTA Picnic , 5-dr MPV, 97-00	A
TOYOTA Picnic , 5-dr MPV, 01-	A
VOLKSWAGEN Golf III , 5-dr Variant, 94-98	B
VOLKSWAGEN Golf III , 3/5-dr Hatchback, 92-97	A
VOLKSWAGEN Passat , 5-dr Variant, 88-97	A
VOLKSWAGEN Sharan , 5-dr MPV, 96-00	B
VOLKSWAGEN Sharan , 5-dr MPV, 01-	B
VOLVO V50 , 5-dr Estate, 04-	B
VOLVO V70 , 5-dr Estate, 00-03	B
VOLVO V70 , 5-dr Estate, 04-07	B

MITSUBISHI Space Gear , 5-dr MPV, 95-	01
MITSUBISHI Space Wagon , 5-dr MPV, 99-03	01
NISSAN Primera (W11) , 5-dr Estate, 97-01	01
NISSAN Terrano (WD21) , 3/5-dr SUV, 88-96	01
OPEL Omega , 5-dr Estate, 94-03	01
OPEL Sintra , 5-dr MPV, 96-99	01
OPEL Vectra , 5-dr Estate, 03-05	01
OPEL Zafira , 5-dr MPV, 98-02	01
OPEL Zafira , 5-dr MPV, 03-04	01
OPEL Zafira , 5-dr MPV, 05-	01
PEUGEOT 405 , 5-dr Estate, 89-97	01
PEUGEOT 806 , 5-dr MPV, 94-02	01
SEAT Alhambra , 5-dr MPV, 96-00	01
SEAT Alhambra , 5-dr MPV, 01-	01
SUBARU Legacy , 5-dr Estate, 89-93	01
SUBARU Legacy , 5-dr Estate, 94-02	01
TOYOTA Avensis , 5-dr Estate, 98-02	01
TOYOTA Avensis Verso , 5-dr MPV, 01-03	01
TOYOTA Carina E , 5-dr Estate, 94-97	01
TOYOTA Picnic , 5-dr MPV, 97-00	01
TOYOTA Picnic , 5-dr MPV, 01-	01
VOLKSWAGEN Golf III , 5-dr Variant, 94-98	01
VOLKSWAGEN Golf III , 3/5-dr Hatchback, 92-97	01
VOLKSWAGEN Passat , 5-dr Variant, 88-97	01
VOLKSWAGEN Sharan , 5-dr MPV, 96-00	01
VOLKSWAGEN Sharan , 5-dr MPV, 01-	01
VOLVO V50 , 5-dr Estate, 04-	01
VOLVO V70 , 5-dr Estate, 00-03	01
VOLVO V70 , 5-dr Estate, 04-07	01

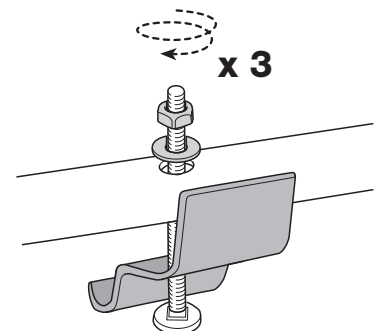
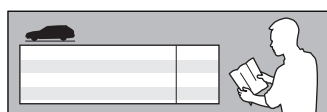
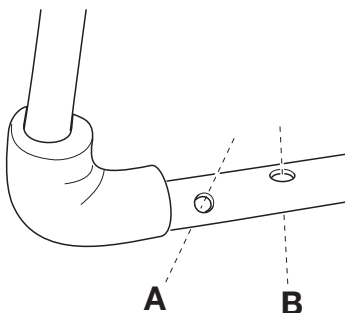
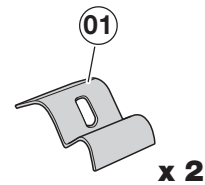
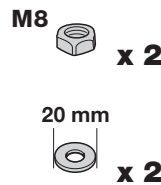
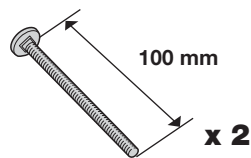
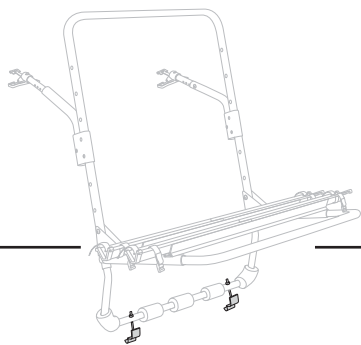

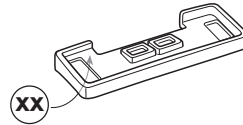

MITSUBISHI Space Gear , 5-dr MPV, 95-	04
MITSUBISHI Space Wagon , 5-dr MPV, 99-03	04
NISSAN Primera (W11) , 5-dr Estate, 97-01	04
NISSAN Terrano (WD21) , 3/5-dr SUV, 88-96	04
OPEL Omega , 5-dr Estate, 94-03	06
OPEL Sintra , 5-dr MPV, 96-99	06
OPEL Vectra , 5-dr Estate, 03-05	04
OPEL Zafira , 5-dr MPV, 98-02	06
OPEL Zafira , 5-dr MPV, 03-04	06
OPEL Zafira , 5-dr MPV, 05-	06
PEUGEOT 405 , 5-dr Estate, 89-97	04
PEUGEOT 806 , 5-dr MPV, 94-02	04
SEAT Alhambra , 5-dr MPV, 96-00	06
SEAT Alhambra , 5-dr MPV, 01-	06
SUBARU Legacy , 5-dr Estate, 89-93	04
SUBARU Legacy , 5-dr Estate, 94-02	04
TOYOTA Avensis , 5-dr Estate, 98-02	04
TOYOTA Avensis Verso , 5-dr MPV, 01-03	04
TOYOTA Carina E , 5-dr Estate, 94-97	06
TOYOTA Picnic , 5-dr MPV, 97-00	04
TOYOTA Picnic , 5-dr MPV, 01-	04
VOLKSWAGEN Golf III , 5-dr Variant, 94-98	04
VOLKSWAGEN Golf III , 3/5-dr Hatchback, 92-97	06
VOLKSWAGEN Passat , 5-dr Variant, 88-97	06
VOLKSWAGEN Sharan , 5-dr MPV, 96-00	06
VOLKSWAGEN Sharan , 5-dr MPV, 01-	06
VOLVO V50 , 5-dr Estate, 04-	04
VOLVO V70 , 5-dr Estate, 00-03	04
VOLVO V70 , 5-dr Estate, 04-07	04

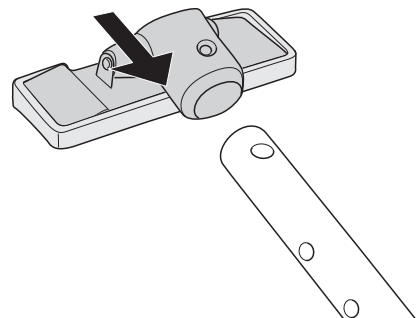
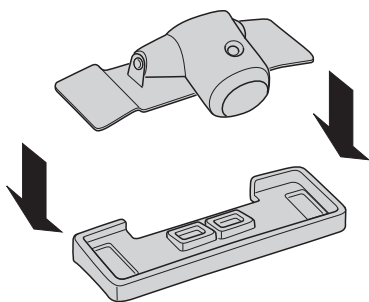
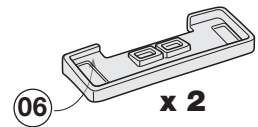
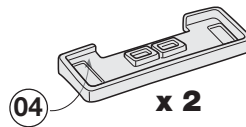
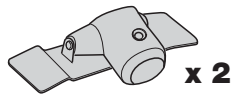
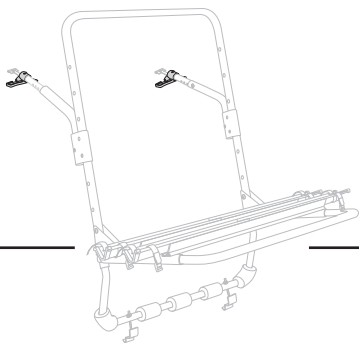

GB Check the settings for your car model in the table; count the number of visible holes.

D Kontrollieren Sie die Einstellungen für Ihr Fahrzeugmodell gemäß Tabelle durch Zählen der sichtbaren Löcher.

F Contrôlez dans le tableau les indications de réglage pour votre voiture. Comptez le nombre de trous visibles.

NL Controleer de instellingen voor uw automodel in de tabel, tel het aantal zichtbare gaten.

I Verificare le impostazioni per il proprio modello di automobile; contare il numero di fori visibili.

E Controle en la tabla la colocación aplicable en su modelo de automóvil; cuente el número de agujeros visibles.

PT Verificar os ajustes para o seu modelo de carro conforme a tabela; conte o número de orifícios visíveis.

S Kontrollera inställningarna för din bilmodell i tabellen, räkna antal synliga hål.

FIN Tarkista taulukosta automallikohtaiset säädöt. Laske näkyvien reikien lukumäärä.

EST Kontrollige tabelist oma masina seadeid; lugege üle nähtavad augud.

LAT Tabulā pārbaudiet jūsu automobiļa modeļa iestatījumus; saskaitiet redzamos caurumus.

LIT Savo automobilio modelio parametrus pasitiklinkite pagal lentelėje pateiktus duomenis; suskaičiuokite matomų angų skaičių.

PL Sprawdź w tabeli ustawienia obowiązujące dla posiadanego samochodu. Policz widoczne otwory.

RU Посмотрите спецификации вашей модели автомобиля в таблице; сосчитайте количество видимых отверстий.

CZ Zkontrolujte nastavení pro svůj model automobilu v tabulce; odpočítejte viditelné otvory.

SK Skontrolujte nastavenia v tabuľke pre model vášho vozidla; spočítajte počet viditeľných dier.

SLO Preverite v tabeli nastavitve za vaš model in tip vozila. Preštejte število vidnih lukenj.

HR U tablici provjerite postavke za vaš model automobila; prebrojite vidljive rupe.

HU Ellenőrizze a saját gépkocsijára vonatkozó beállításokat a táblázaton; számolja meg a látható furatokat.

GR Ελέγξτε τις ρυθμίσεις για το μοντέλο του αυτοκινήτου σας στον πίνακα και μετρήστε τον αριθμό των ορατών τρυπών.

TR Tablodan araba modelinizin ayarlarını kontrol edin; görünebilir delik sayısını sayın.

中文 在表中查看适合您的车型的装配方式; 数一下可看到的孔的个数。

日本語 ご使用の車体モデルの設定を表で確認し、見える穴の数を数えてください。

한국어 표에서 차종별 설정을 확인하여 보이는 구멍의 개수를 확인하십시오.

ไทย ตรวจสอบการติดตั้งสำหรับรถยนต์รุ่นของคุณในตารางนี้ นับจำนวนรูที่มองเห็น

6

MITSUBISHI Space Gear, 5-dr MPV, 95-	9/99mm
MITSUBISHI Space Wagon, 5-dr MPV, 99-03	8/88mm
NISSAN Primera (W11), 5-dr Estate, 97-01	5/55mm
NISSAN Terrano (WD21), 3/5-dr SUV, 88-96	6/66mm
OPEL Omega, 5-dr Estate, 94-03	4/44mm
OPEL Sintra, 5-dr MPV, 96-99	6/66mm
OPEL Vectra, 5-dr Estate, 03-05	11/121mm
OPEL Zafira, 5-dr MPV, 98-02	5/55mm
OPEL Zafira, 5-dr MPV, 03-04	5/55mm
OPEL Zafira, 5-dr MPV, 05-	8/88mm
PEUGEOT 405, 5-dr Estate, 89-97	6/66mm
PEUGEOT 806, 5-dr MPV, 94-02	7/77mm
SEAT Alhambra, 5-dr MPV, 96-00	4/44mm
SEAT Alhambra, 5-dr MPV, 01-	5/55mm
SUBARU Legacy, 5-dr Estate, 89-93	12/132mm
SUBARU Legacy, 5-dr Estate, 94-02	11/121mm
TOYOTA Avensis, 5-dr Estate, 98-02	3/33mm
TOYOTA Avensis Verso, 5-dr MPV, 01-03	4/44mm
TOYOTA Carina E, 5-dr Estate, 94-97	3/33mm
TOYOTA Picnic, 5-dr MPV, 97-00	5/55mm
TOYOTA Picnic, 5-dr MPV, 01-	5/55mm
VOLKSWAGEN Golf III, 5-dr Variant, 94-98	3/33mm
VOLKSWAGEN Golf III, 3/5-dr Hatchback, 92-97	4/44mm
VOLKSWAGEN Passat, 5-dr Variant, 88-97	5/55mm
VOLKSWAGEN Sharan, 5-dr MPV, 96-00	4/44mm
VOLKSWAGEN Sharan, 5-dr MPV, 01-	5/55mm
VOLVO V50, 5-dr Estate, 04-	12/132mm
VOLVO V70, 5-dr Estate, 00-03	9/99mm
VOLVO V70, 5-dr Estate, 04-07	9/99mm

7

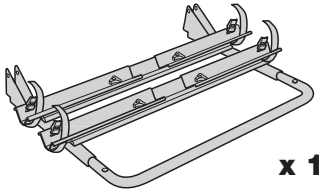

x 1

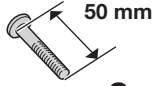

x 2



x 2

M6



x 2

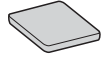

x 2

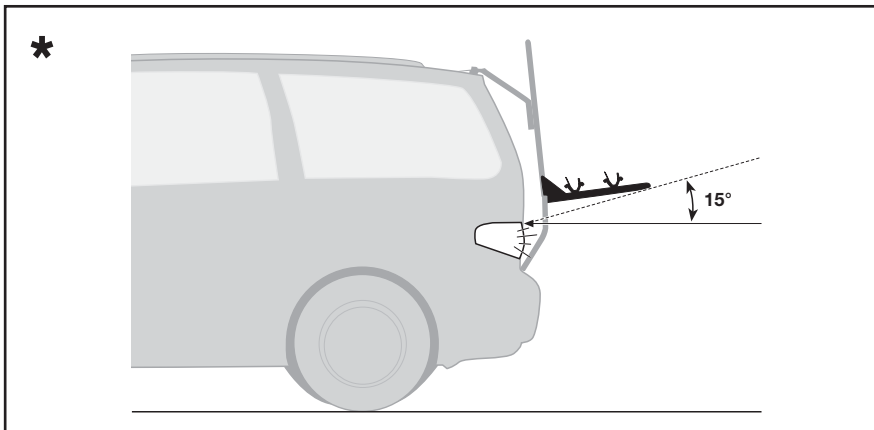
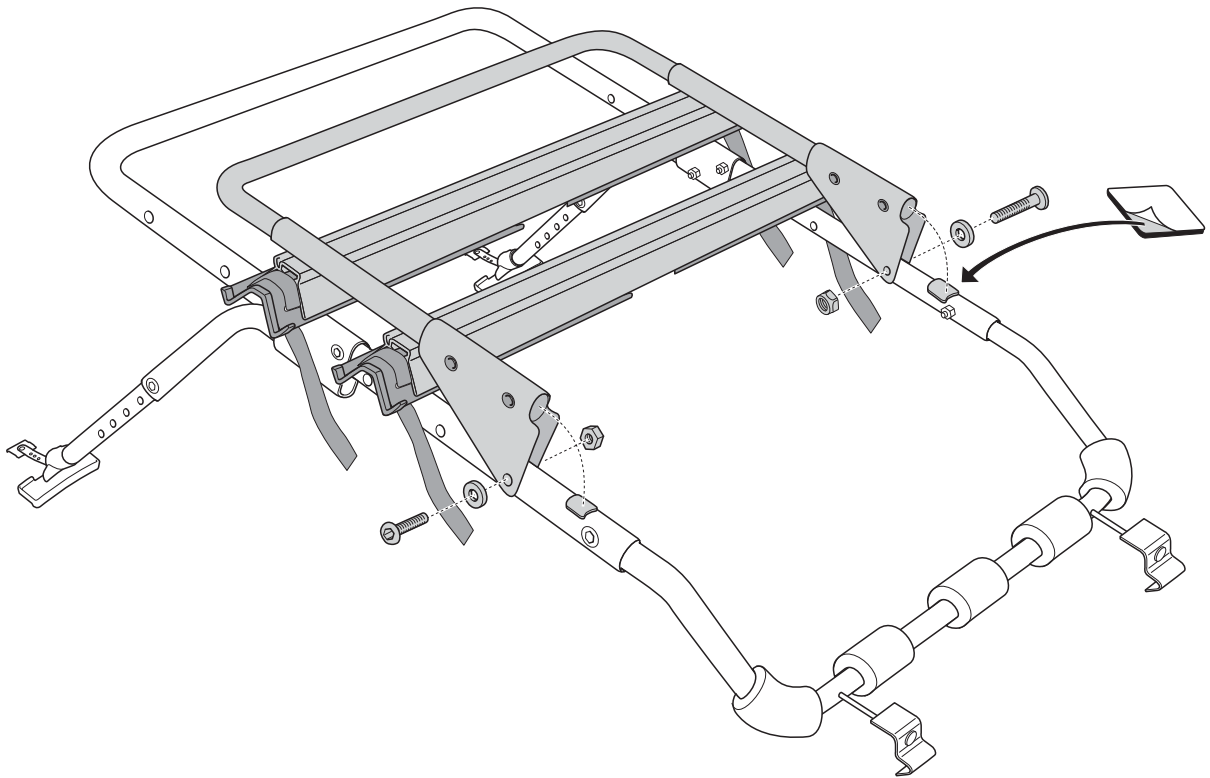

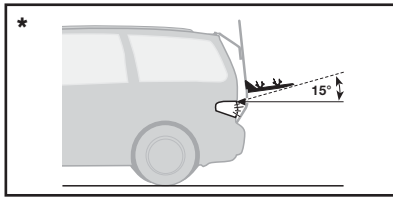

GB IMPORTANT!

In order for the vehicle to be allowed to be driven on the road, some countries require that the car's tail lights and number plate be visible at an angle of 15° upwards. Make sure that your car meets this regulation if it applies in the country in which you are travelling. If it does not, raise the bike shelf one hole.

D WICHTIG!

In einigen Ländern ist vorgeschrieben, daß die Rücklichter und das Kennzeichen in 15° Winkel nach oben erkennbar sind. Wenn diese Forderung nicht erfüllt ist, die Fahrradkonsole um ein Loch nach oben versetzen.

F IMPORTANT!

La législation exige dans certains pays que la plaque d'immatriculation et les feux arrière soient visibles sous un angle de 15° vers le haut lorsque la voiture roule. Contrôler dans ce cas qu'ils le sont. Sinon, relever l'arceau de l'équivalent de la distance au trou suivant.

NL BELANGRIJK!

In sommige landen mag de auto alleen worden gebruikt als de achterlichten en de nummerplaat tot een hoek van 15° naar boven zichtbaar zijn. Zorg ervoor dat dit het geval is of plaats anders de fietsplank een gat hoger.

I IMPORTANTE!

In alcuni Paesi, il codice della strada impone che le luci di posizione e la targa del veicolo debbano essere visibili ad un angolo di 15° verso l'alto. Accertarsi che la propria automobile sia conforme alle norme vigenti nel Paese visitato. In caso contrario, sollevare la mensola per bicicletta di un foro.

E IMPORTANTE!

Para que el vehículo pueda conducirse por carretera, en algunos países se exige que la luz de cola del automóvil y la placa de la matrícula sean visibles por un ángulo hacia arriba de 15°. Si esta norma tiene vigencia en el país por el que viaja, asegúrese de que su automóvil cumpla con ella. De no ser así, eleve el estante de bicicleta un agujero.

PT IMPORTANTE

Para que o veículo possa circular em rodovias, alguns países exigem que as luzes traseiras e a placa devem estar visíveis em um ângulo de 15° para cima. Certifique-se de que seu veículo atende aos regulamentos em vigor no país por onde viaja. Caso contrário, eleve a prateleira de bicicletas em um orifício.

S VIKTIGT!

För att fordonet skall få framföras krävs i vissa länder att bakljus och nummerplåt är synliga i en vinkel på 15° uppåt. Försäkra dig om att så är fallet. I annat fall höjs cykelhyllan ett hål.

FIN TÄRKEÄ!

Joissakin maissa ajoneuvolla ajo on sallittua vain, kun ajoneuvon takavalot ja rekisterikilpi ovat nähtävissä 15° asteen kulmasta ylöspäin. Jos mainittua säännöstä sovelletaan siinä maassa, jossa autoilet, varmista, että autosi täyttää säännöksen vaatimukset. Jos vaatimukset eivät täyty, nosta pyöränkannatin yhtä reikää ylempiä.

EST TÄHTIS!

Et lubada sõidukit teel pukseerida, nõuavad mõned riigid, et auto tagatud ja numbrimärk oleksid nähtavad 15° võrra ülespoole. Veenduge, et Teie auto vastab selle riigi nõudmistele, kuhu Te reisite. Kui ei vasta, tõstke jalgrattariilit ühe augu võrra.

LAT SVARIGI!

Dažās valstīs, lai ar transportlīdzekli varētu pārvietoties pa ceļu, automobiļa aizmugures lukturiem un numura plāksnītei jābūt redzamiem 15° leņķī, skatoties no augšas. Ja valstī, kurā atrodaties, pastāv šāda prasība, pārlicinieties, ka jūsu automobiļs tai atbilst. Ja neatbilst, pārvietojiet velosipēdu turcītāju par vienu caurumu uz augšu.

LIT SVARBU

Kai kuriose šalyse važiuoti keliais leidžiama tik tomis transporto priemonėmis, kurių galiniai žibintai ir valstybinis numeris matomi 15° kampū iš viršaus. Įsitinkite, kad jūsų automobilis atitinka šį reikalavimą, jei jis galioja valstybėje, kurioje keliaujate. Jei automobilis reikalavimo neatitinka, pakelkite dviračių lentynėlę aukštyr per vieną angą.

PL WAŻNE!

W niektórych krajach, aby pojazd był dopuszczony do ruchu drogowego, jego tylnie światła i tylna tablica rejestracyjna muszą być widoczne z góry pod kątem 15°. Jeśli przepis taki obowiązuje w kraju podróży, należy sprawdzić, czy samochód spełnia ten warunek. Jeśli nie, należy podnieść półkę z rowerami o jeden otwór.

501-7291-02

RU ВАЖНО!

В некоторых странах установлены ограничения для автомобилей на некоторых видах дорог, задние фонари и номерные знаки должны быть видны под углом 15° вверх. В случае путешествия на автомобиле в стране, в которой установлено такое требование, убедитесь, что автомобиль соответствует ему. Если требование не соблюдается, поднимите кронштейн велосипеда на одно отверстие.

CZ DŮLEŽITÉ!

Aby bylo možné automobil používat na silnici, je v některých zemích vyžadováno, aby byla světla zadních dveří a poznávací značka viditelná z horního úhlu 15°. Pokud toto nařízení platí v zemi, ve které cestujete, ujistěte se, že jej automobil splňuje. Pokud ne, zvedněte stojan kola o jeden otvor.

SK DÔLEŽITÉ

Aby bola možná prevádzka vozidla na komunikáciách, je v niektorých štátoch povinné, aby zadné svetlá a poznávací značka vozidla boli viditeľné aj pod uhlom väčším ako 15°. Ak vozidlo používate v krajine, ktorá má takýto predpis, uistite sa, že vaše vozidlo tieto požiadavky spĺňa. Ak tomu tak nie je, zdvihnite držiak bicyklov o jednu diery.

SLO PAZITE!

Zakon v nekaterih državah zahteva, da so zadnje luči in registrska tablica vidna pod kotom 15° stopinj, prepričajte se, da vaš prtljajnik ustreza zahtevam države v kateri ste in v katero potujete. Nosilec za kolesa lahko dvignete glede na niz lukenj v okvirju.

HR VAŽNO

Kako bi automobil dobio dozvolu za vožnju, neke države zahtijevaju da stražnja svjetla i registracijske oznake budu vidljivi pod kutom od najmanje 15°. Provjerite zadovoljava li vaš automobil ta pravila ako ona vrijede u državi u kojoj putujete. U protivnom podignite nosač na sljedeću rupu.

HU FONTOS!

Egyes országokban a közúti közlekedés egyik feltétele, hogy a gépkocsi hátsó lámpái és a rendszám tábla 15° fokban láthatók legyenek. Győződjön meg arról, hogy gépkocsija megfelel azon ország szabályainak, ahol utazik. Amennyiben nem, akkor emelje meg a kerékpártartót egy furattal.

GR ΣΗΜΑΝΤΙΚΟ

Για να επιτραπεί η κίνηση του αυτοκινήτου στο δρόμο, ορισμένες χώρες απαιτούν να είναι ορατά τα πίσω φώτα και η πινακίδα κυκλοφορίας του οχήματος από μία γωνία 15° και άνω. Βεβαιωθείτε πως το αυτοκίνητό σας τηρεί αυτό τον κανονισμό αν αυτός ισχύει στη χώρα στην οποία ταξιδεύετε. Αν δεν τον τηρεί, σηκώστε το θράψι του ποδηλάτου κατά μία τρύπα.

TR ÖNEMLİ

Aracın yolda sürülebilmesi için, bazı ülkelerde 15° üzeri açılarda kuyruk lambaların ve plakanın görünür olması zorunludur. Seyahat ettiğiniz ülkede böyle bir düzenleme varsa, arabanızın bu düzenlemeye uygun olduğundan emin olun. Arabanız uygun durumda değilse, bisiklet rafını bir delik kaldırın.

中文 重要事項!

为使汽车获准在公路上行驶，一些国家要求从上方 15° 角方向能够看到汽车尾灯和车号牌。如果您在实行此规定的国家旅行，请确保您的汽车满足规定要求。如果该国无此规定，则可将自行车架的位置提高一个孔。

日本語 重要!

国によっては、車を路上で運転するには、車のテールライトおよびナンバープレートが上方 15° の角度で見える必要がある場合があります。走行する国でこの規則が適用される場合、ご使用の車がこの規則に合致しているかを確認してください。合致していない場合、自転車シェルフを 1 穴分上げてください。

한국어 중요!

일부 국가의 경우, 도로에서 차량을 주행하려면 차량의 후방등과 번호판이 위쪽 15°에서 보여야 합니다. 위와 같은 법규가 여행 중인 국가에 해당하는지 여부를 확인하십시오. 법규가 해당하는 경우, 자전거 선반을 구멍 하나 높이만큼 올리십시오.

ไทย ข้อสำคัญ

เพื่ออนุญาตให้ขับขี่รถยนต์บนถนนได้ บางประเทศกำหนดให้ไฟท้ายและป้ายทะเบียนรถต้องมองเห็นได้ในมุมองศา 15 องศา โปรดแน่ใจว่ารถยนต์ของคุณสอดคล้องกับระเบียบข้อบังคับนี้หากบังคับใช้ในประเทศที่คุณกำลังเดินทาง หากไม่สอดคล้องให้เลื่อนชั้นวางจักรยานขึ้นหนึ่งรู

8



x 2

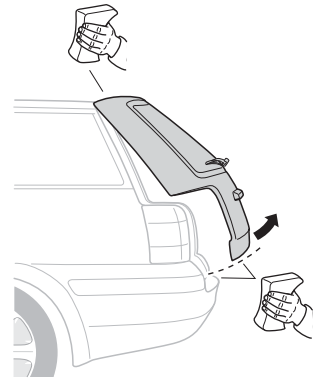
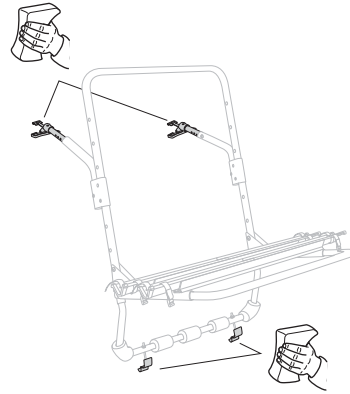

CC

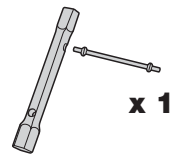
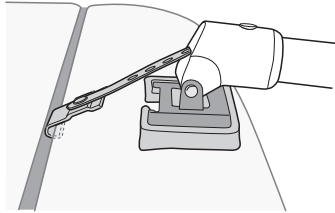
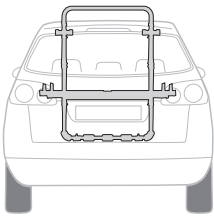

x 1

5 Nm

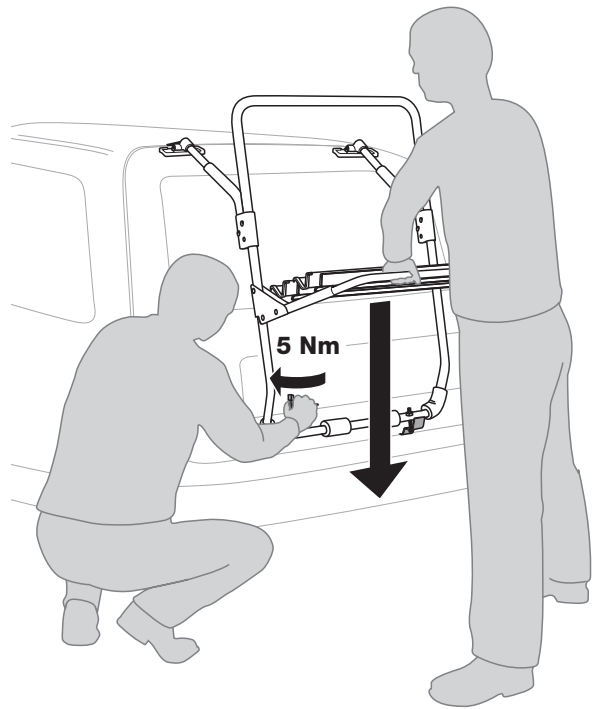
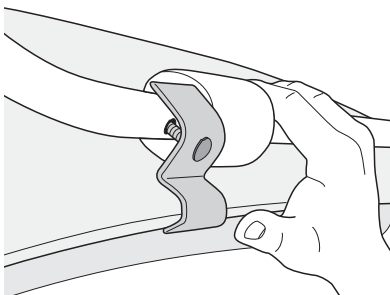
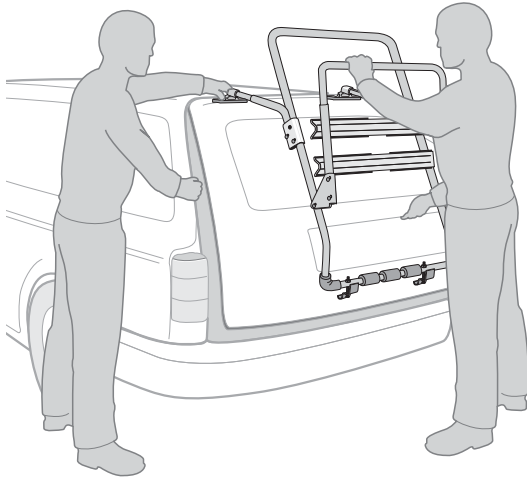

9

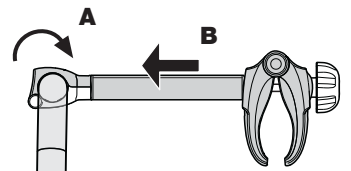
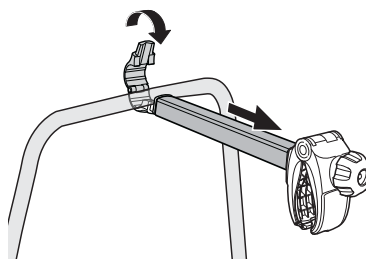
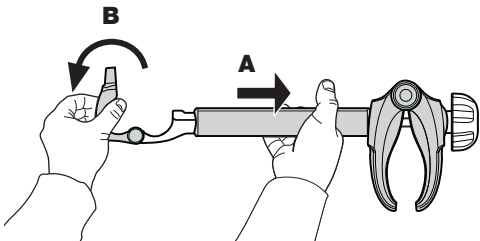
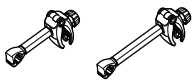

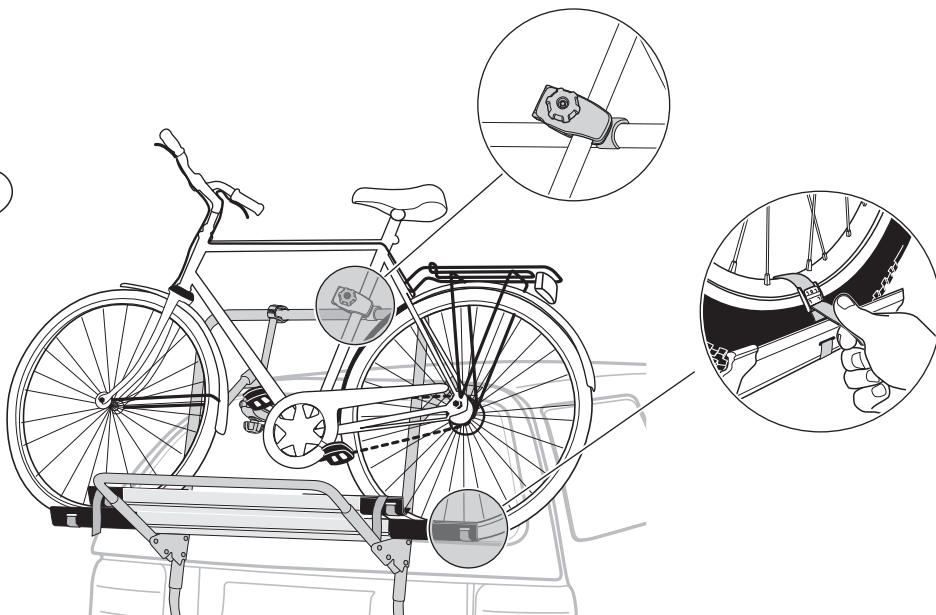
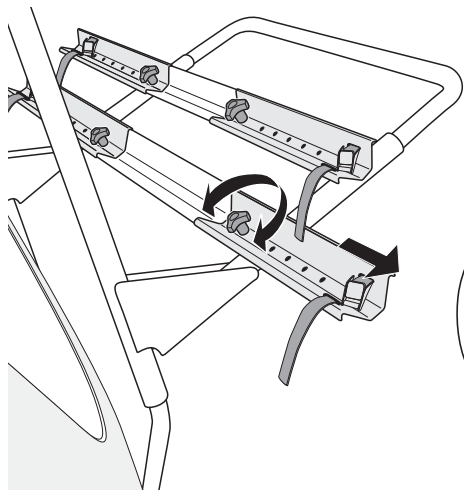

GB Accessories
D Zubehör
F Accessoires
NL Accessoires
I Accessori
E Accesorios
PT Acessórios
S Tillbehör
FIN Lisävarusteet

EST Lisavarustus
LAT Piederumi
LIT Priedai
PL Akcesoria
RU Аксессуары
CZ Doplnky
SK Príslušenstvo
SLO Dodatki
HR Dodaci

HU Tartozékok
GR Παρελκόμενα
TR Aksesuarlar
中文 附件
日本語 付属品
한국어 액세서리
ไทย อุปกรณ์เสริม

526



538



567

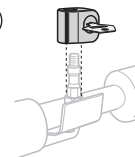

9902



973

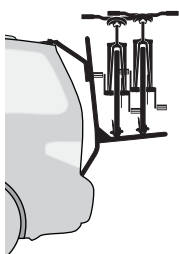

973-23

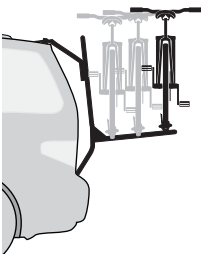

3 kg

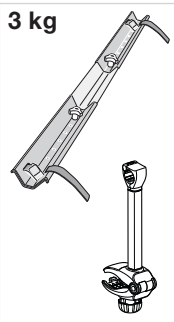

973-24

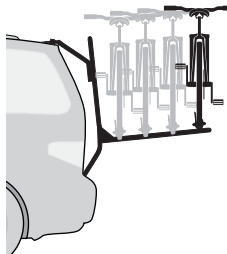

3 kg

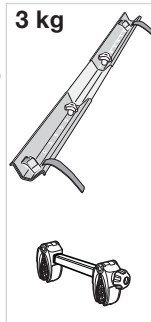

i

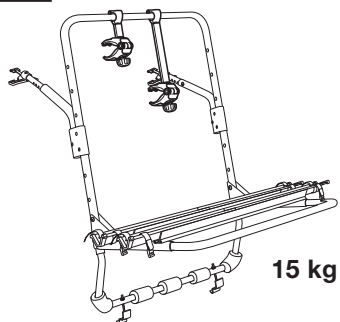

15 kg

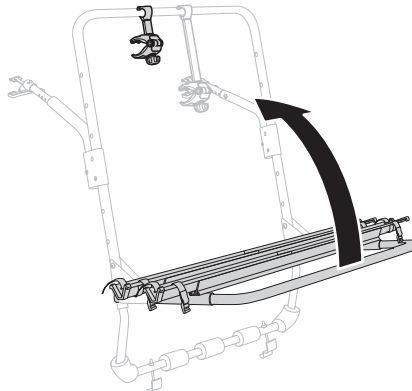

THULE[®]
 SWEDEN

Box 69, 330 33 Hillerstorp, SWEDEN
 www.thule.com