

Se não houver instruções no seu idioma, entre em contato com os funcionários do estabelecimento para obter informações

Eğer talimatlar dilinizde basılı değilse, lütfen atölye personelinden bilgi isteyiniz.

Αν οι οδηγίες δεν εκτυπώνονται στη γλώσσα σας, παρακαλούμε ζητήστε πληροφορίες από το προσωπικό του καταστήματος.

ถ้าไม่มีคำแนะนำในภาษาของคุณ โปรดติดต่อพนักงานในร้านเพื่อขอข้อมูล

**THULE**<sup>®</sup>  
SWEDEN

- S** Monteringsanvisning
- GB** Fitting instructions
- D** Montageanleitung
- F** Instructions de montage
- NL** Montage-instructies
- FIN** Asennusohje
- E** Instrucciones de montaje
- I** Istruzioni per il montaggio
- CZ** Návod na montáž
- PL** Instrukcja montażu
- HU** Szerelési utasítások
- RU** Инструкции по установке
- EST** Paigalduseeskirjad
- SLO** Navodila za pritrjevanje

한국어 장착 지침

日本語 取扱(取付)説明書

**Kit 207**  
1061-1-207

- DODGE Stealth, 3-dr Coupé, 92-96*
- MITSUBISHI 3000 GT, 3-dr Coupé, 93-98*
- MITSUBISHI GTO, 3-dr Coupé, 93-98*
- MITSUBISHI Magna, 4-dr Sedan, 97-*

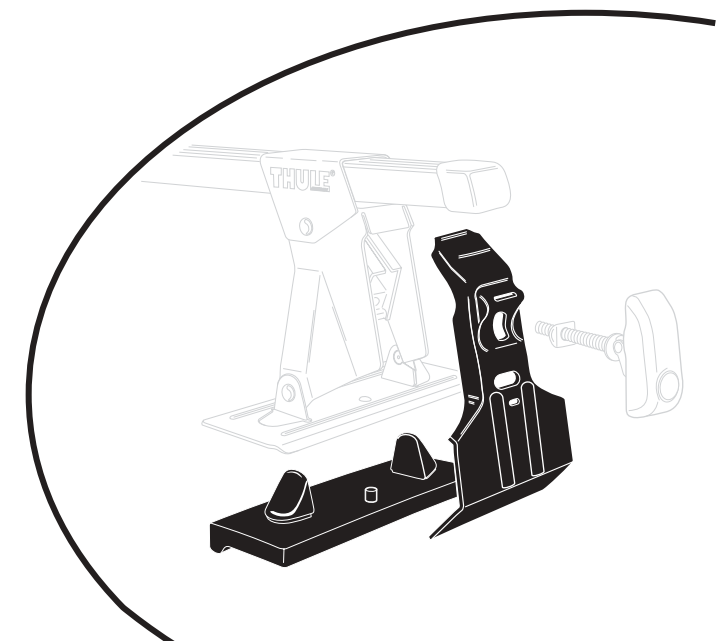

**Follow me...**

**THULE**<sup>®</sup>  
SWEDEN

Box 69, 330 33 Hillerstorp, SWEDEN  
www.thule.com

403\*3DF2/501-0207-03

1

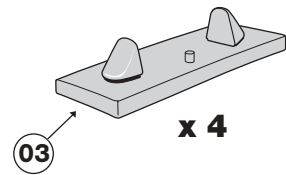

x 4

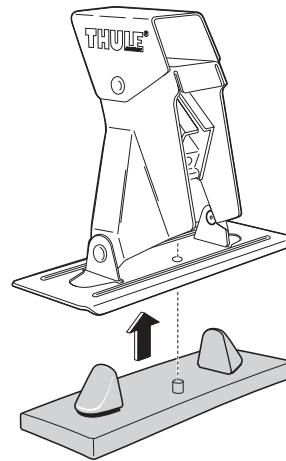

2

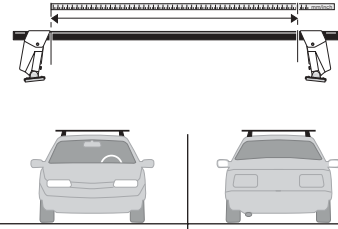

<b>DODGE Stealth,</b> 3-dr Coupé, 92-96	940 mm 37 inch	940 mm 37 inch
<b>MITSUBISHI 3000 GT,</b> 3-dr Coupé, 93-98	940 mm 37 inch	940 mm 37 inch
<b>MITSUBISHI GTO,</b> 3-dr Coupé, 93-98	940 mm 37 inch	940 mm 37 inch
<b>MITSUBISHI Magna,</b> 4-dr Sedan, 97-	1000 mm 39 3/8 inch	1000 mm 39 3/8 inch

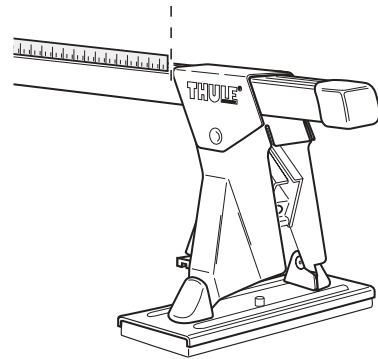

3

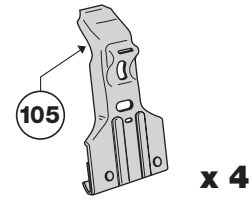

x 4

**DODGE Stealth,** 3-dr Coupé, 92-96  
**MITSUBISHI 3000 GT,** 3-dr Coupé, 93-98  
**MITSUBISHI GTO,** 3-dr Coupé, 93-98

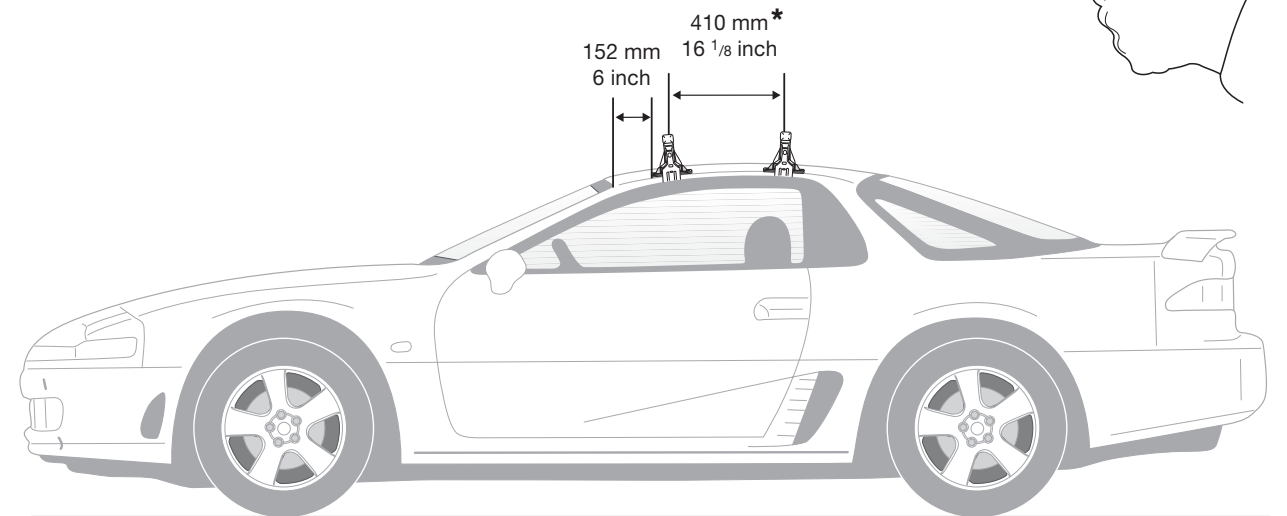
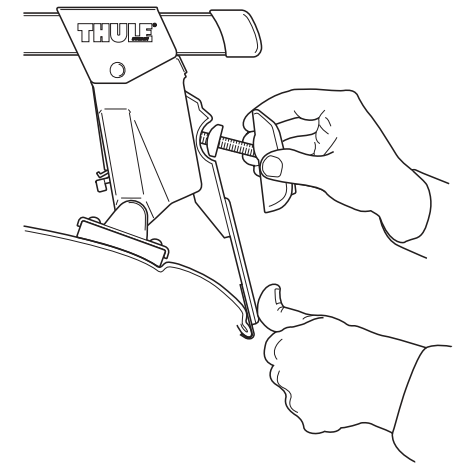

3

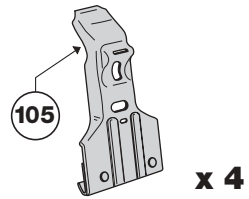

x 4

**MITSUBISHI Magna,** 4-dr Sedan, 97-

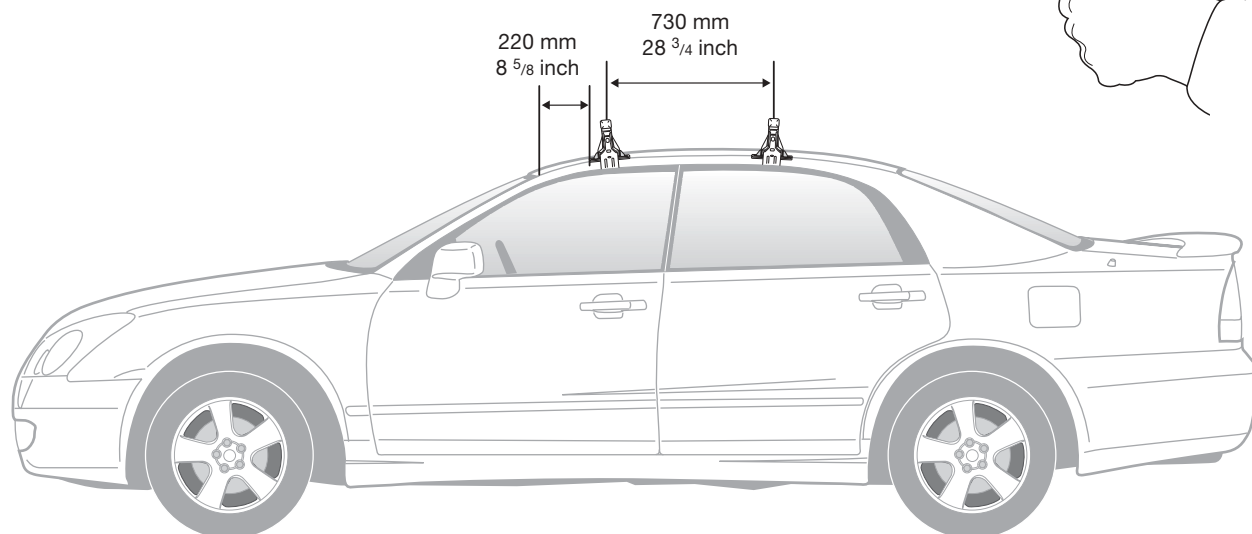
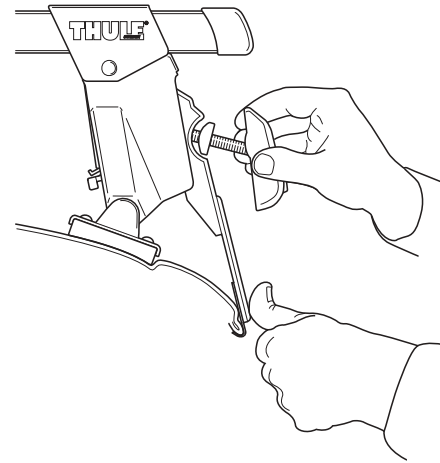

\* 410 mm  
16 1/8 inch

- S** **VIKTIGT!** Pga det korta monteringsavståndet mellan fästpunkterna får ej boxar, surfbrädor, cyklar eller andra långa föremål monteras.
- GB** **IMPORTANT!** As the distance between the load bars is short, roof boxes, surfboards, bikes and other long loads should not be transported.
- D** **WICHTIG!** Aufgrund des geringen Montageabstandes zwischen den Bogen des Lastenträgers dürfen keine Dachboxen, Surfbretter, Fahrräder andere lange Gegenstände montiert werden.
- F** **IMPORTANT!** Les points de fixation étant relativement rapprochés, il ne faut pas monter sur le porte-charges d'objets longs tels que coffre, surf, vélos ou autres.
- NL** **BELANGRIJK!** Vanwege de korte montage-afstand tussen de bevestigingspunten mogen er geen combi-boxen, surfplanken, fietsen of andere lange voorwerpen gemonteerd worden.
- FIN** **TÄRKEÄÄ!** Kiinnityspisteiden lyhyen asennusvälin vuoksi ei telineelle saa asentaa kuljetuslaatikoita, purjelautoja, polkupyöriä tai muita pitkiä esineitä.
- E** **IMPORTANTE!** Debido a la corta distancia de montaje entre los apoyos, no deben montarse cajas de techo, tablas de surf, bicicletas ni otros objetos largos.
- I** **IMPORTANTE!** A causa della ridotta distanza tra le barre portatutto, non trasportare box portapacchi, tavole da surf, biciclette ed altri carichi lunghi

- CZ** **POZOR!** Vzhledem ke krátké montážní vzdálenosti mezi úchyty nelze namontovat nákladové boxy, surfovací prkna, kola či jiné dlouhé předměty.
- PL** **UWAGA!** Ze względu na krótki odstęp między punktami zamocowania nie wolno zakładać skrzyń, desek do surfowania, rowerów lub innych długich przedmiotów.
- HU** **FONTOS!** Amennyiben a két alpartót túl közel rögzítjük egymáshoz, akkor a tetőboxok, szőrtartók, kerékpártartók és más kiegészítők nem szállíthatók
- RU** **ВАЖНО!** Ввиду малого расстояния между поперечинами не рекомендуется перевозка боксов, досок для серфинга, велосипедов и прочих длинномерных грузов
- EST** **TÄHTIS!** Kuna kandetalade vahemaa on lühike, ei tohiks transportida katusebokse, lainelaudu, jalgrataid ja teisi pikki laadungeid.
- SLO** **POMEMBNO!** Zaradi prekratke razdalje med palicama dolgih tovorov, kot so surfi, kolesa in strešni kovčki, ni dovoljeno prevažati.
- 한국어** **중요!** 적재 바 사이의 간격이 짧으면 루프 박스, 서핑보드, 자전거 등 길이가 긴 짐을 실을 수 없습니다.
- 日本語** **重要!** 積荷バー間の距離が短いため、ルーフボックス、サーフボード、自転車などの長さのある積荷は運搬しないでください。