

# Kit 1565

**FORD Focus**, 3-dr Hatchback, \*98-03, 04–

**FORD Focus**, 5-dr Hatchback, \*98-03, 04–

**FORD Focus**, 4-dr Sedan, \*98-03, 04–

**FORD Focus**, 5-dr Wagon, \*98-03, 04–

\*North America

480R  
754

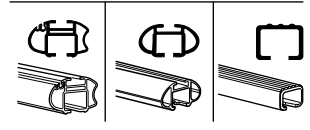
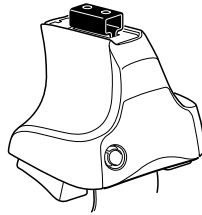

480

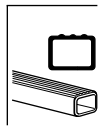
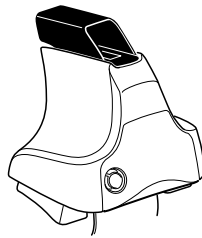

750

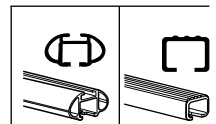
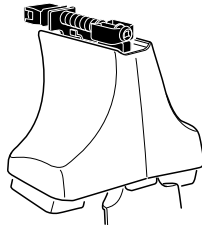

**THULE**<sup>®</sup>  
SWEDEN

ISO 11154-E

**Kit**

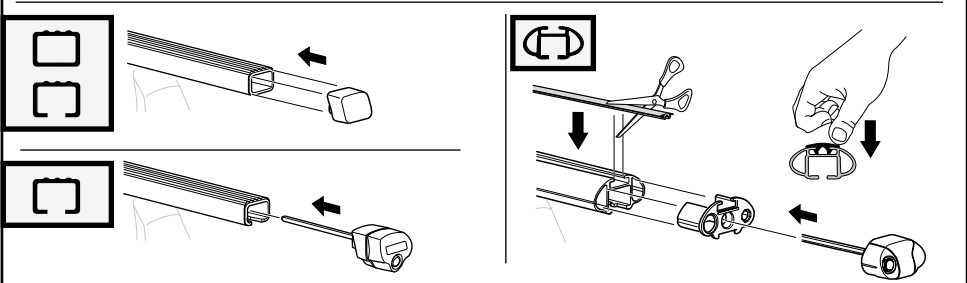
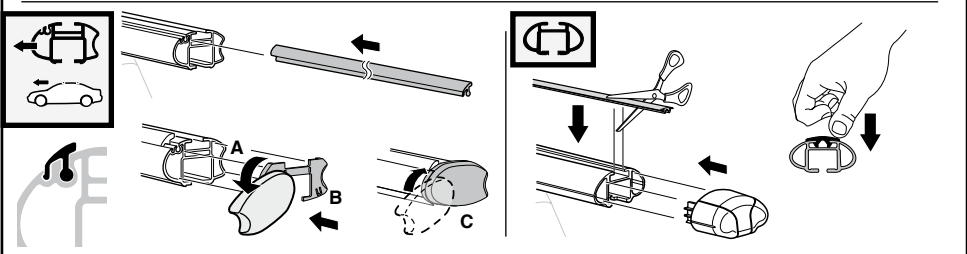
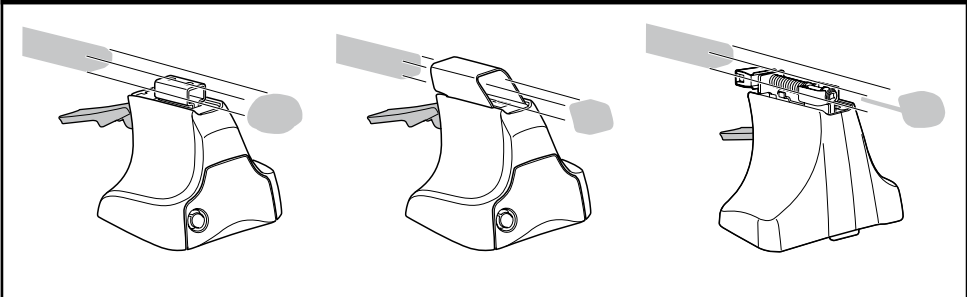
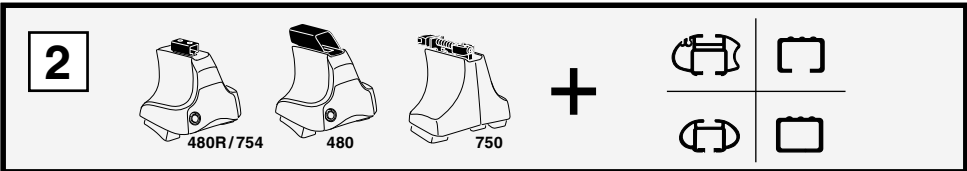
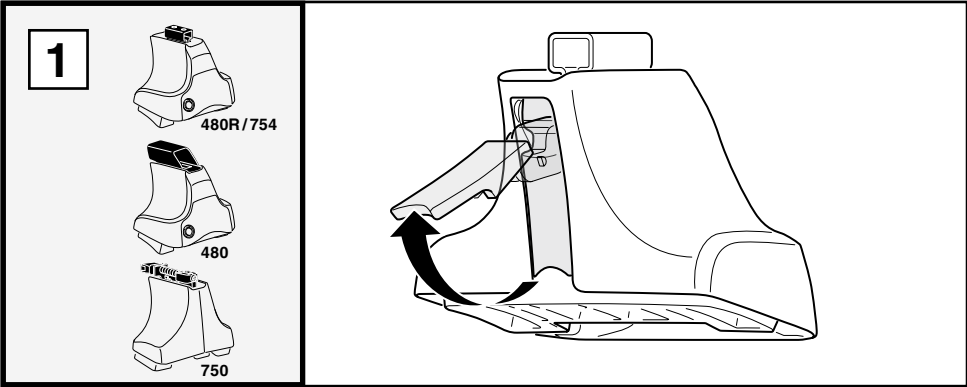

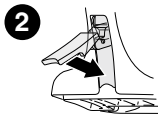
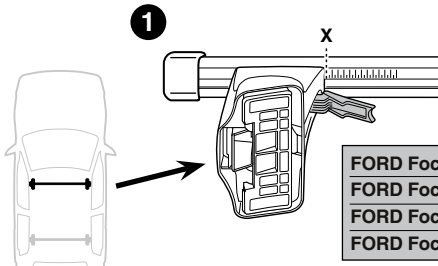
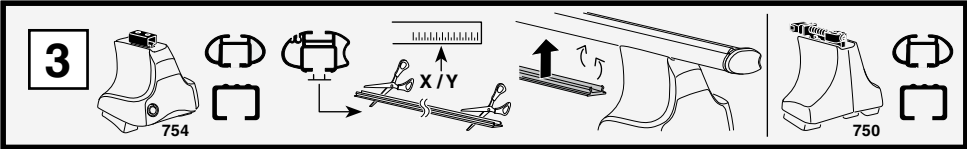

	X
FORD Focus, 3-dr Hatchback, *98-03, 04-	33,5
FORD Focus, 5-dr Hatchback, *98-03, 04-	32,5
FORD Focus, 4-dr Sedan, *98-03, 04-	32,5
FORD Focus, 5-dr Wagon, *98-03, 04-	32

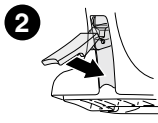
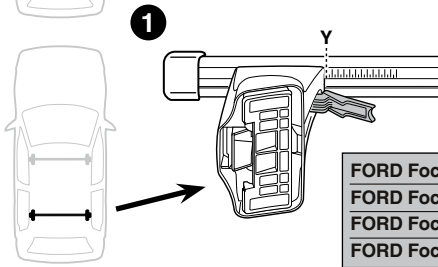

	Y
FORD Focus, 3-dr Hatchback, *98-03, 04-	28
FORD Focus, 5-dr Hatchback, *98-03, 04-	29
FORD Focus, 4-dr Sedan, *98-03, 04-	30
FORD Focus, 5-dr Wagon, *98-03, 04-	28,5

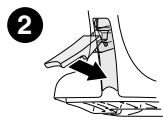
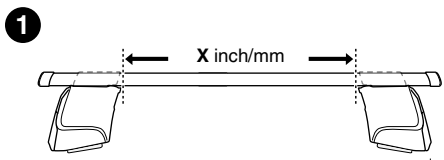
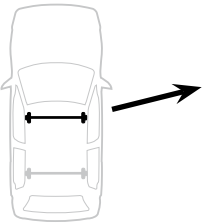
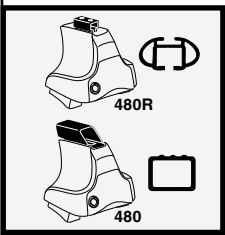

	X inch	X mm
FORD Focus, 3-dr Hatchback, *98-03, 04-	38 <sup>7</sup> / <sub>8</sub> "	986 mm
FORD Focus, 5-dr Hatchback, *98-03, 04-	38 <sup>3</sup> / <sub>8</sub> "	976 mm
FORD Focus, 4-dr Sedan, *98-03, 04-	38 <sup>3</sup> / <sub>8</sub> "	976 mm
FORD Focus, 5-dr Wagon, *98-03, 04-	38 <sup>1</sup> / <sub>4</sub> "	971 mm

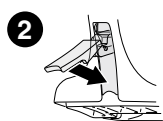
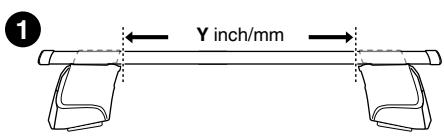
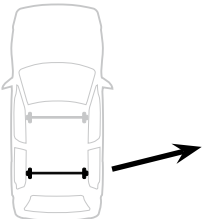

	X inch	X mm
FORD Focus, 3-dr Hatchback, *98-03, 04-	36 <sup>5</sup> / <sub>8</sub> "	931 mm
FORD Focus, 5-dr Hatchback, *98-03, 04-	37	941 mm
FORD Focus, 4-dr Sedan, *98-03, 04-	37 <sup>1</sup> / <sub>2</sub> "	951 mm
FORD Focus, 5-dr Wagon, *98-03, 04-	36 <sup>7</sup> / <sub>8</sub> "	936 mm

4

FORD Focus, 3-dr Hatchback, \*98-03, 04-

SRA

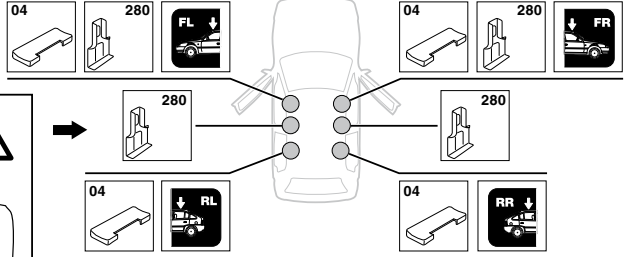
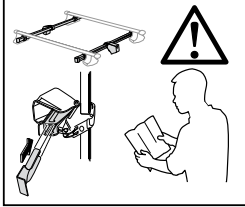

FORD Focus, 5-dr Hatchback, \*98-03, 04-

FORD Focus, 4-dr Sedan, \*98-03, 04-

FORD Focus, 5-dr Wagon, \*98-03, 04-

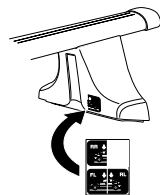
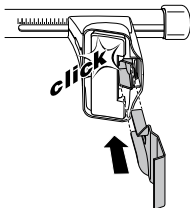
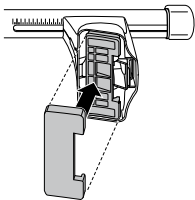
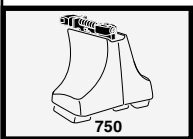
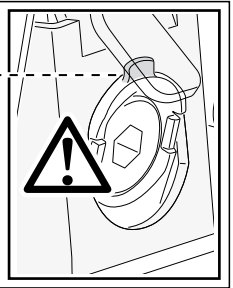
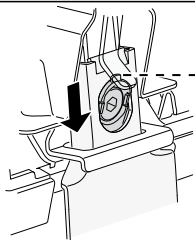
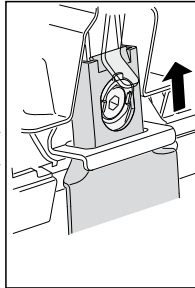
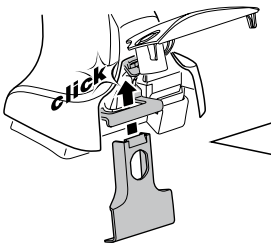
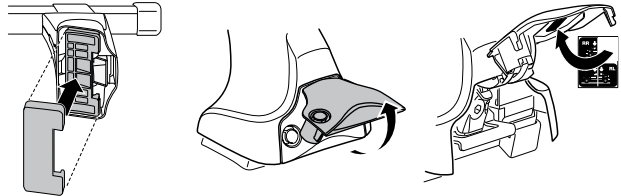
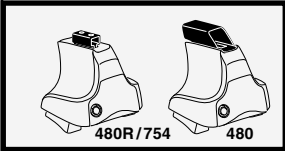
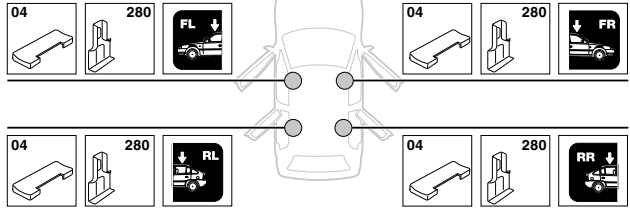

5

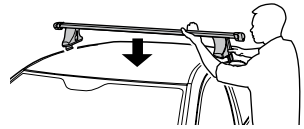
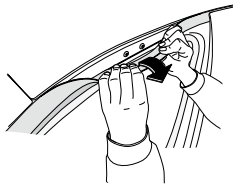
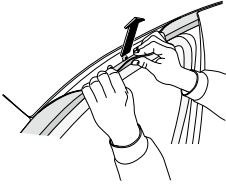

**FORD Focus, 3-dr Hatchback, \*98-03, 04-**

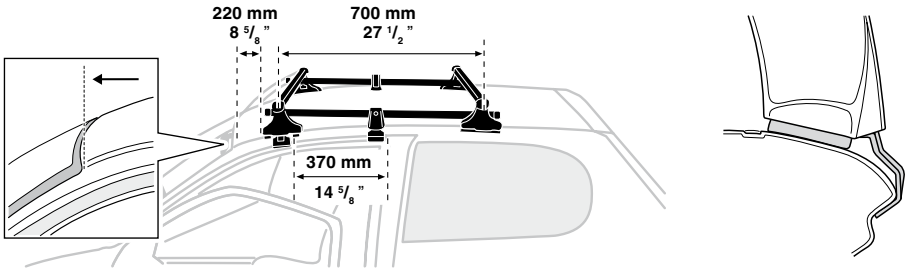

	X mm	Y mm	X inch	Y inch
<b>FORD Focus, 5-dr Hatchback, *98-03, 04-</b>	220 mm	630 mm	8 5/8"	24 3/4"
<b>FORD Focus, 4-dr Sedan, *98-03, 04-</b>	220 mm	630 mm	8 5/8"	24 3/4"
<b>FORD Focus, 5-dr Wagon, *98-03, 04-</b>	220 mm	630 mm	8 5/8"	24 3/4"

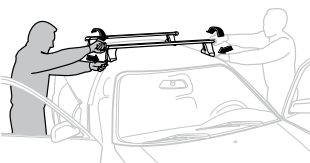
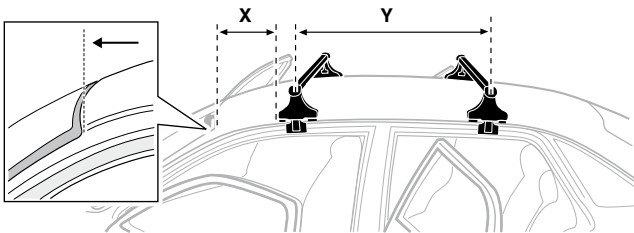

**GB/US** Tighten alternately  
**D** Die Schrauben abwechselnd anziehen  
**F** Serrer alternativement chaque côté  
**NL** Afwisselend aan de linker- en de rechterkant aandraaien  
**I** Alternare il serraggio delle viti  
**E** Apretar alternativamente  
**PT** Aperte alternadamente  
**S** Dra åt växelvis  
**FIN** Kierrä vuorotellen  
**EST** Pinguldage vaheldumisi  
**LAT** Pievelciēt pamišus  
**LIT** Užsukinėkite pakaitomis  
**PL** Śruby dokręcaj naprzemiennie  
**RU** Затягивайте попеременно

**CZ** Pokręťta багаžníka dokręcaj dokręcaj naprzemiennie.  
**SK** Doťahujte striedavo  
**SLO** Privijajte izmenično.  
**HR** Naizmjениčno zategnite  
**HU** Egymástól függetlenül szorítandó  
**GR** Σφιγγεται εναλλάξ  
**TR** Dönüşümlü sıkın  
**中文** 交替拧紧  
**한국어** 번갈아 가며 조이십시오.  
**日本語** 交互に締め付けてください。  
**ไทย** ชั้้นโน้บแบบสลับ

6

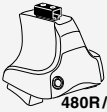

480R/754



480

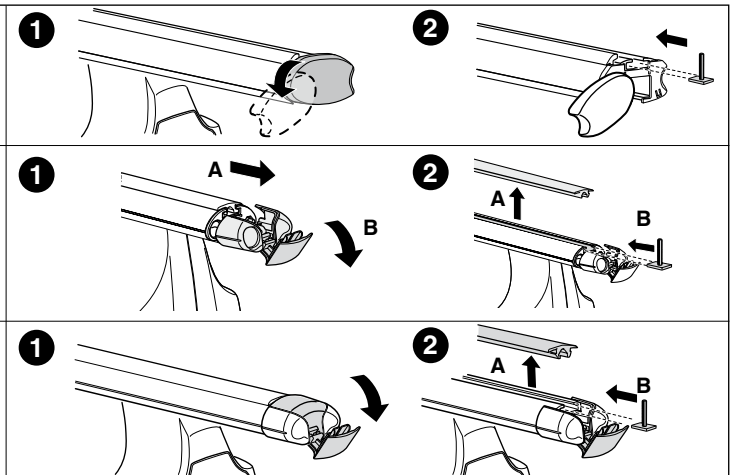
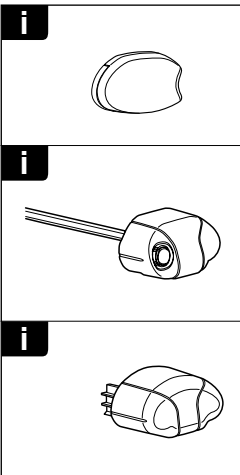
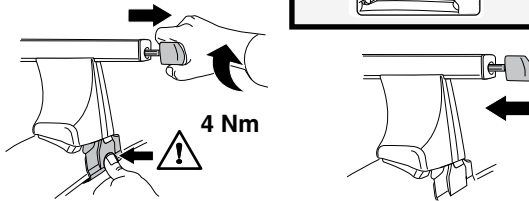
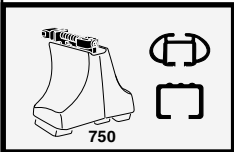
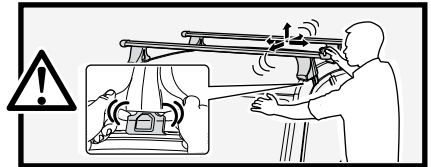
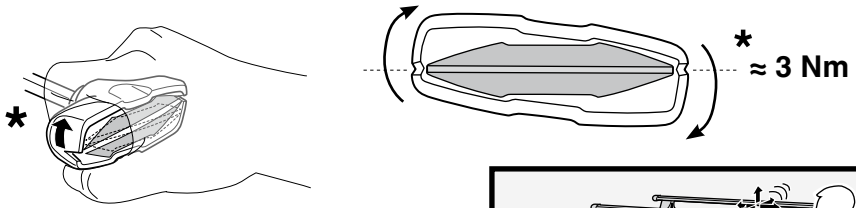
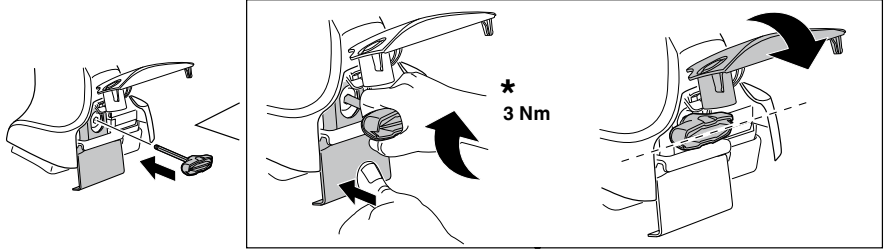

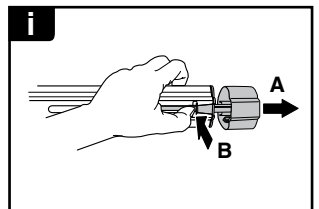
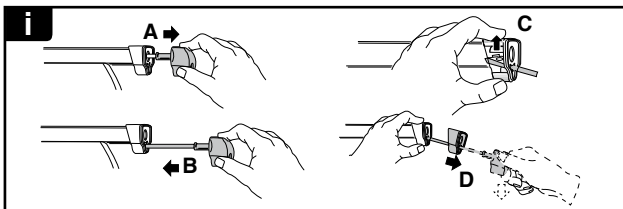
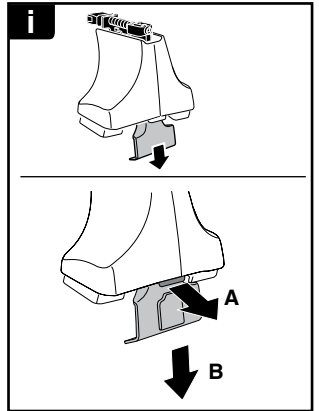
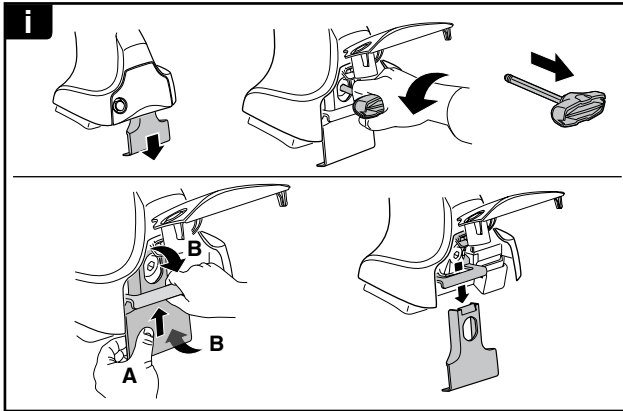
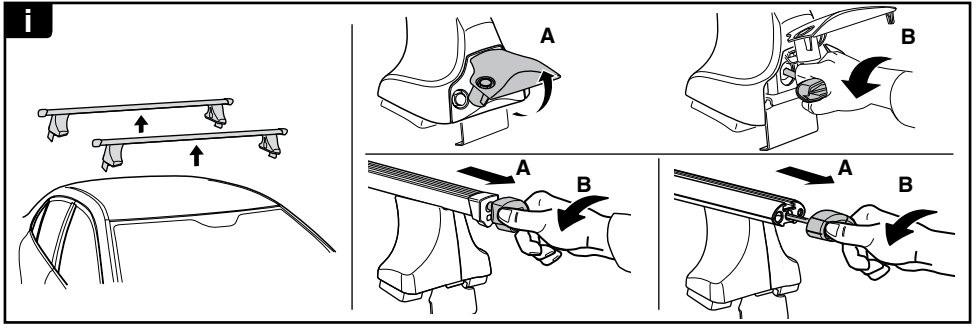

**THULE**  
SWEDEN  
**ONE  
KEY  
SYSTEM**

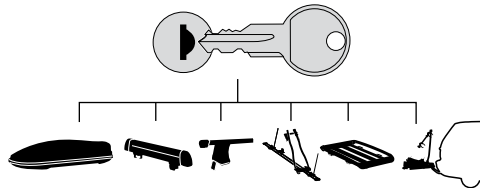

		(x4)
		(x6)
		(x8)
NA		(x10)
EUR		(x12)
ASIA		(x12)

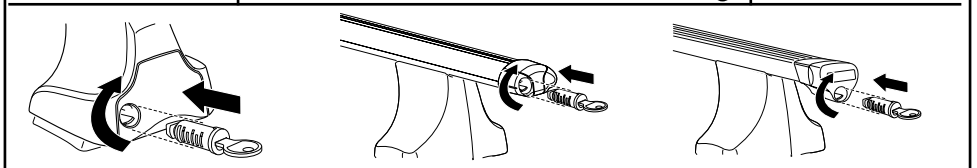

WW ▶ Thule Sweden AB, Box 69, 330 33 Hillerstorp, SWEDEN  
NA ▶ Thule Inc., 42 Silvermine Road, Seymour, Connecticut 06483, USA

info@thule.com  
customer.service@thule.com

www.thule.com