

Kit 1236

MITSUBISHI Pajero Sport, 5-dr SUV, 96-05

MITSUBISHI Challenger, 5-dr SUV, 96-05

MITSUBISHI L200 (Mk 1), 4-dr Double Cab, 95-05

480R
754

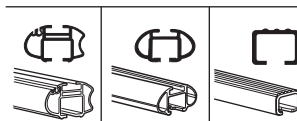
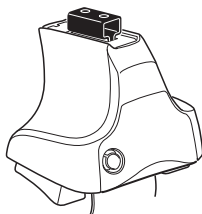

480

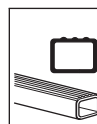
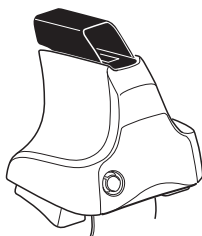

750

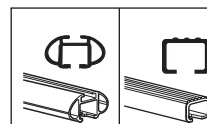
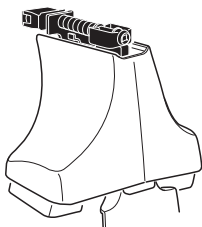

THULE[®]
SWEDEN

Kit

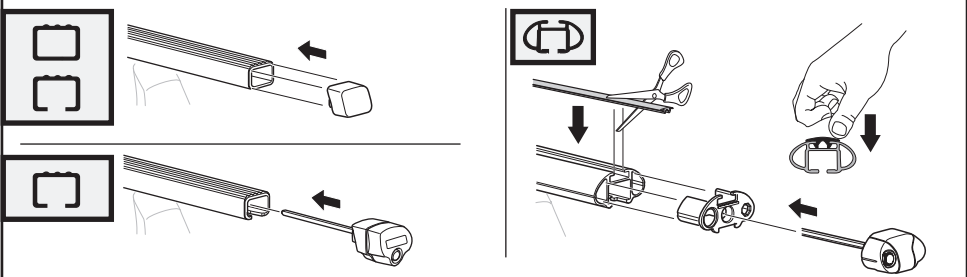
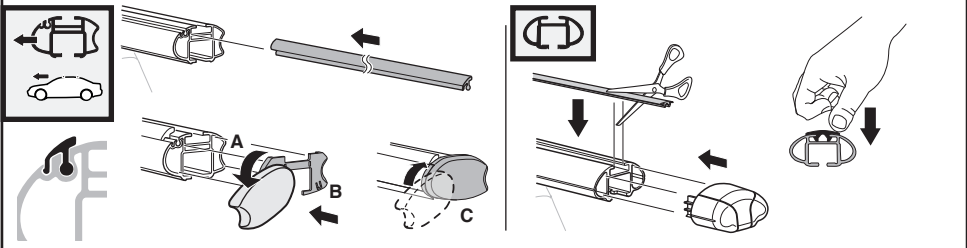
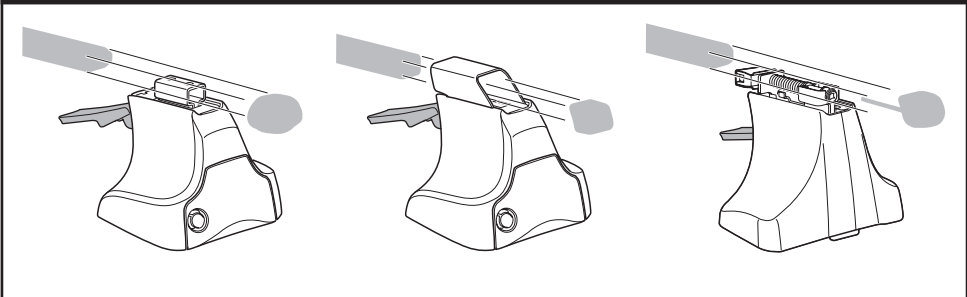
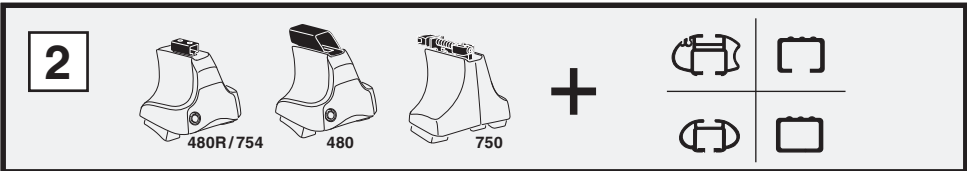
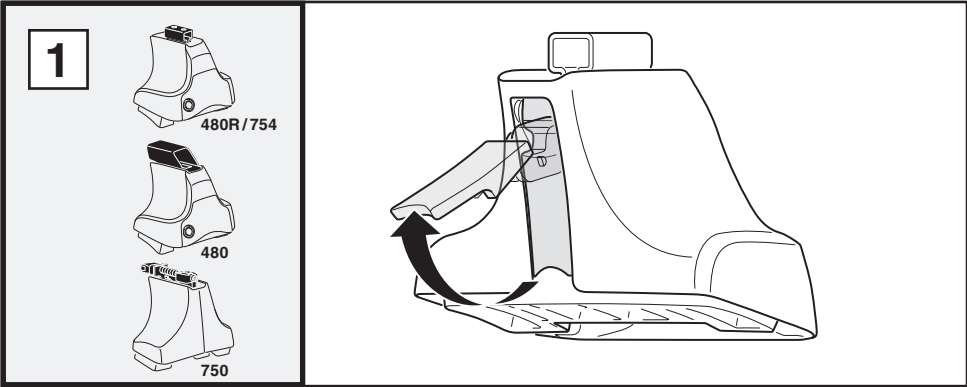

3

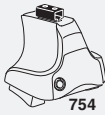

754

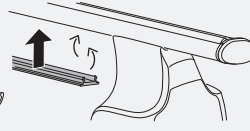
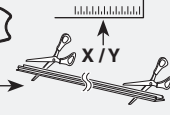

750



1

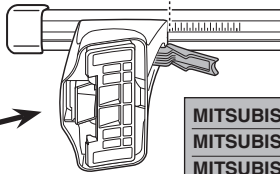
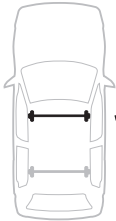

2

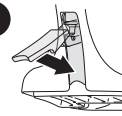

	X
MITSUBISHI Pajero Sport, 5-dr SUV, 96-05	35,5
MITSUBISHI Challenger, 5-dr SUV, 96-05	35,5
MITSUBISHI L200 (Mk 1), 4-dr Double Cab, 95-05	35,5

1

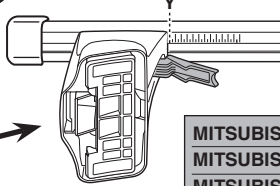

2

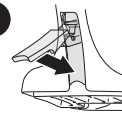

	Y
MITSUBISHI Pajero Sport, 5-dr SUV, 96-05	35,5
MITSUBISHI Challenger, 5-dr SUV, 96-05	35,5
MITSUBISHI L200 (Mk 1), 4-dr Double Cab, 95-05	37



480R



480

1

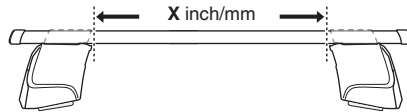

2

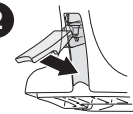

	X inch	X mm
MITSUBISHI Pajero Sport, 5-dr SUV, 96-05	39 ⁵ / ₈ "	1006 mm
MITSUBISHI Challenger, 5-dr SUV, 96-05	39 ⁵ / ₈ "	1006 mm
MITSUBISHI L200 (Mk 1), 4-dr Double Cab, 95-05	39 ⁵ / ₈ "	1006 mm

1

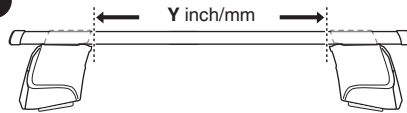

2

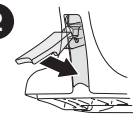

	Y inch	Y mm
MITSUBISHI Pajero Sport, 5-dr SUV, 96-05	39 ⁵ / ₈ "	1006 mm
MITSUBISHI Challenger, 5-dr SUV, 96-05	39 ⁵ / ₈ "	1006 mm
MITSUBISHI L200 (Mk 1), 4-dr Double Cab, 95-05	40 ¹ / ₄ "	1021 mm

4

MITSUBISHI Pajero Sport, 5-dr SUV, 96-05
 MITSUBISHI Challenger, 5-dr SUV, 96-05
 MITSUBISHI L200 (Mk 1), 4-dr Double Cab, 95-05

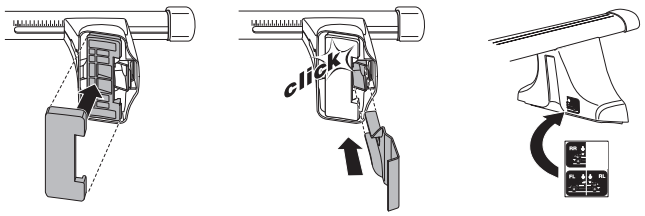
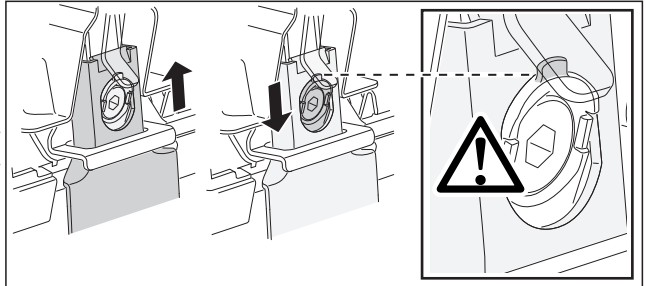
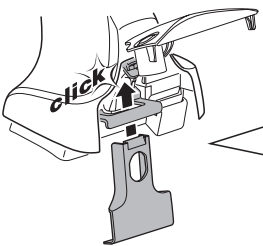
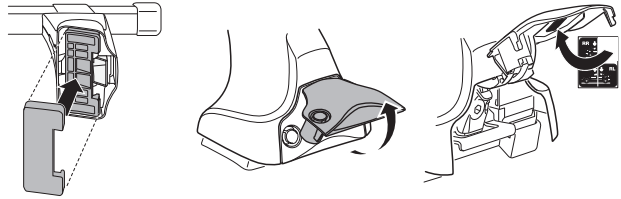
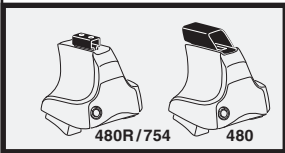
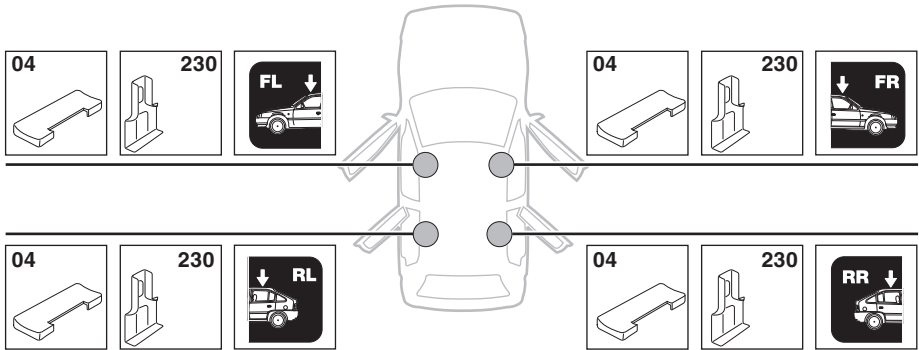

5

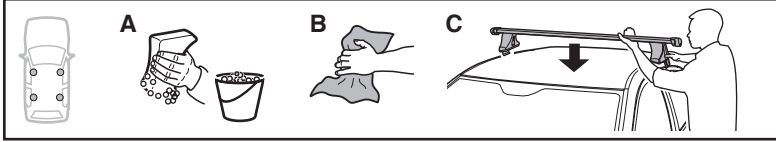

	X mm	Y mm	X inch	Y inch
MITSUBISHI Pajero Sport , 5-dr SUV, 96-05	440mm	700 mm	17 ³ / ₈ ''	27 ¹ / ₂ ''
MITSUBISHI Challenger , 5-dr SUV, 96-05	440 mm	700 mm	17 ³ / ₈ ''	27 ¹ / ₂ ''
MITSUBISHI L200 (Mk 1) , 4-dr Double Cab, 95-05	280 mm	750 mm	11''	29 ¹ / ₂ ''

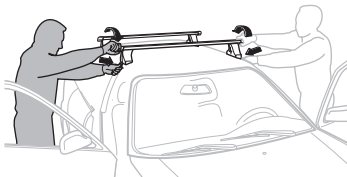
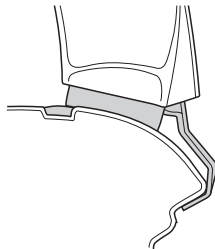
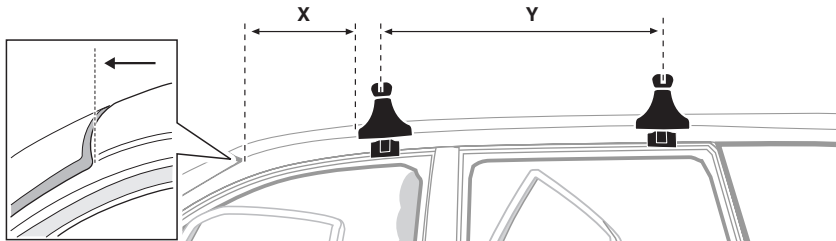

GB/US Tighten alternately

D Die Schrauben abwechselnd anziehen

F Serrer alternativement chaque côté

NL Afwisselend aan de linker- en de rechterkant aandraaien

I Alternare il serraggio delle viti

E Apretar alternativamente

PT Aperte alternadamente

S Dra åt växelvis

FIN Kierrä vuorotellen

EST Pinguldage vaheldumisi

LAT Pievelciet pamišus

LIT Užsukinėkite pakaitomis

PL Śruby dokręcaj naprzemiennie

RU Затягивайте попеременно

CZ Pokręťta багаžníka dokręcaj dokręcaj naprzemiennie.

SK Dotiahujte striedavo

SLO Privijajte izmenično.

HR Naizmjenično zategnite

HU Egymástól függetlenül szorítandó

GR Σφιγγετε εναλλάξ

TR Dönüşümlü sıkın

中文 交替拧紧

한국어 번갈아 가며 조이십시오.

日本語 交互に締め付けてください。

ไทย ชับในแบบสลับ

6



480R/754



480

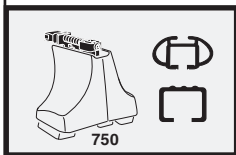
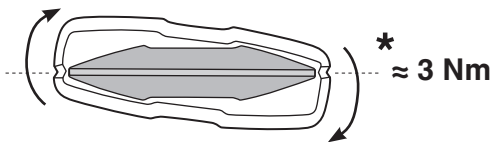
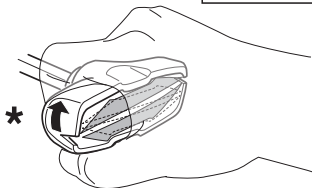
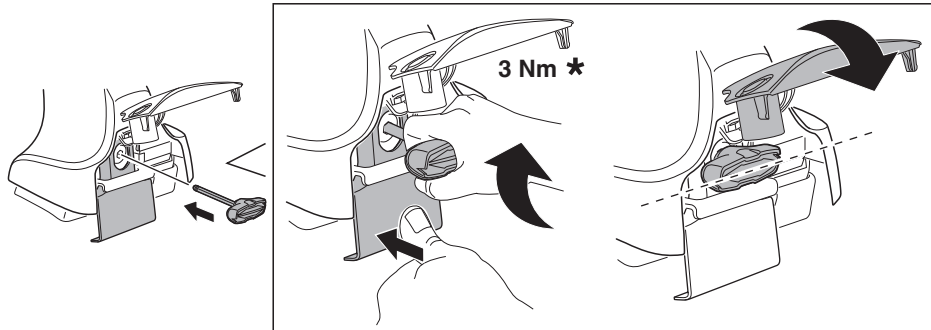

750

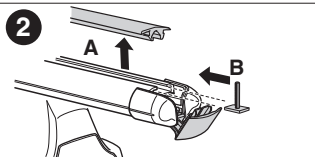
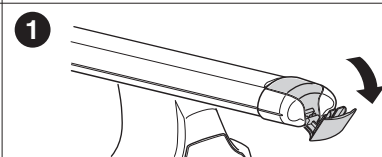
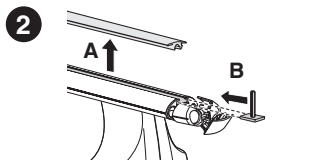
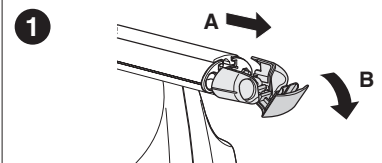
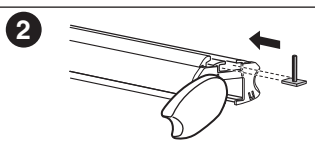
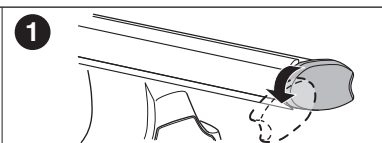
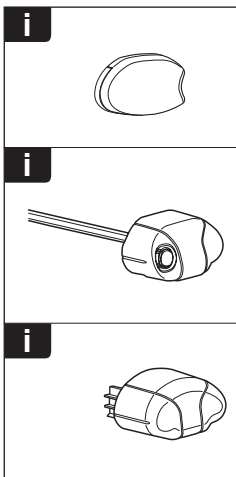
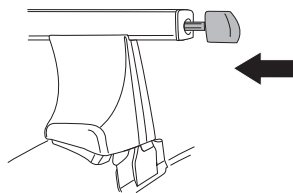
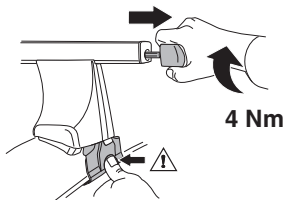

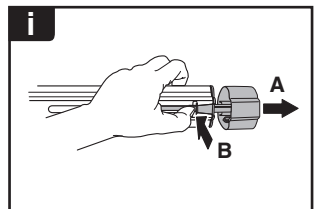
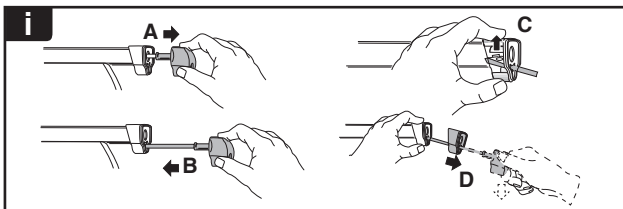
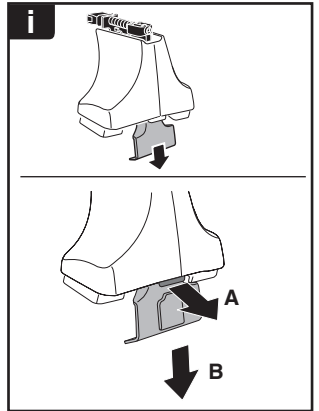
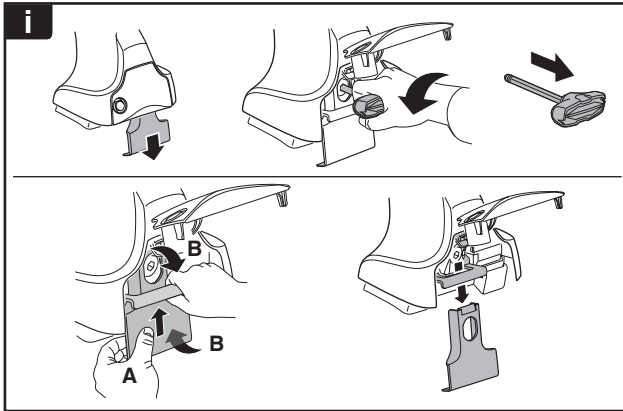
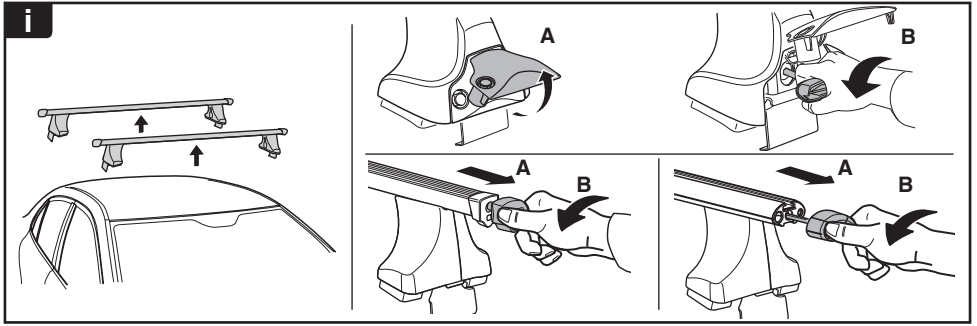

THULE
SWEDEN
**ONE
KEY
SYSTEM**

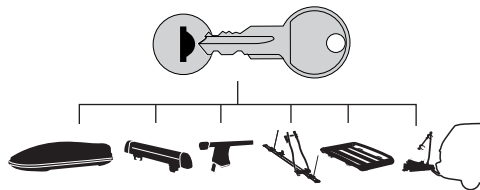

- 544 (x4)
- 596 (x6)
- 588 (x8)
- NA 510 (x10)
- EUR 452 (x12)
- ASIA

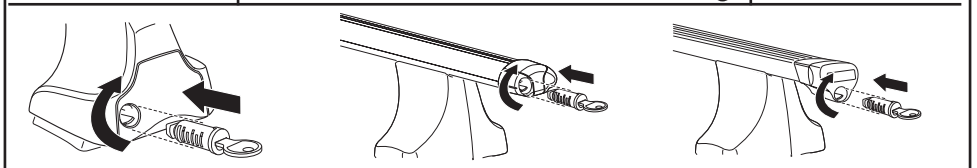

WW ▶ Thule Sweden AB, Box 69, 330 33 Hillerstorp, SWEDEN
NA ▶ Thule Inc., 42 Silvermine Road, Seymour, Connecticut 06483, USA

info@thule.com
customer.service@thule.com

www.thule.com



www.thuleprofessional.com



customer.service@thule.com
info@thule.com



Thule Inc., 42 Silvermine Road, Seymour, Connecticut 06483, USA
Thule Sweden AB, Box 69, 330 33 Hillerstorp, SWEDEN

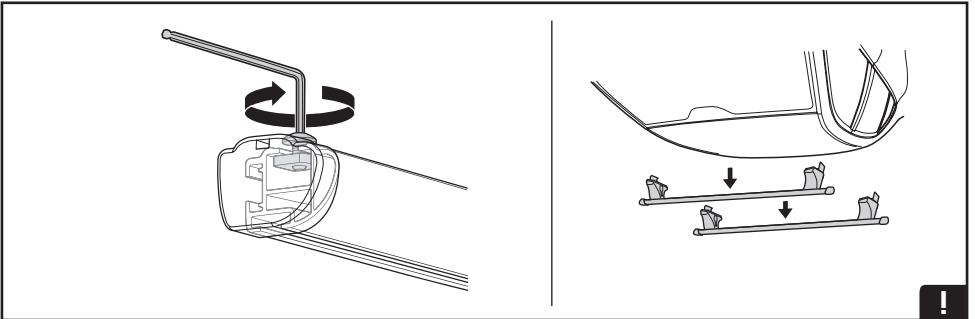
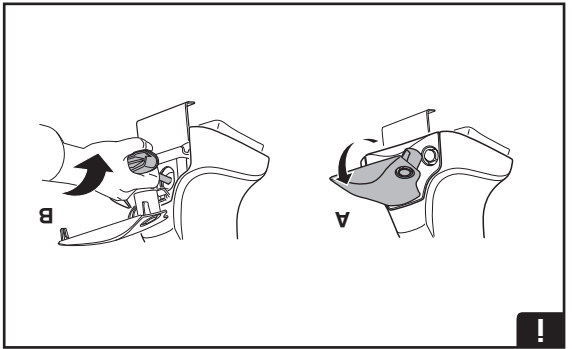
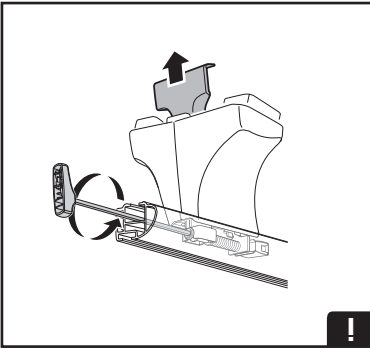
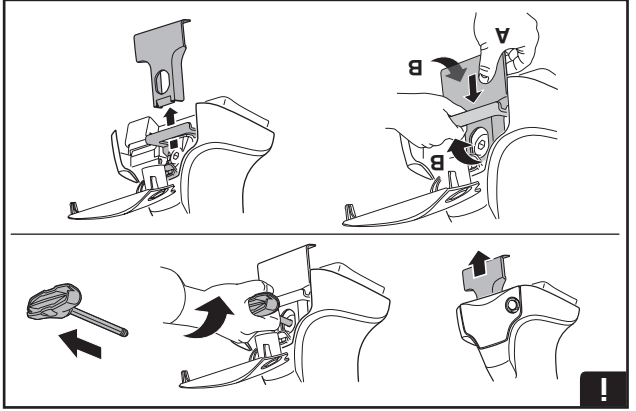
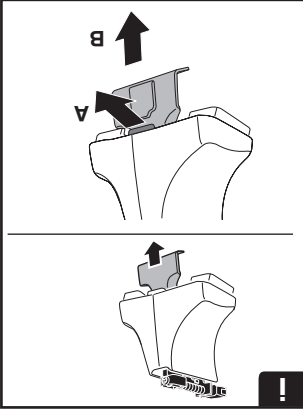

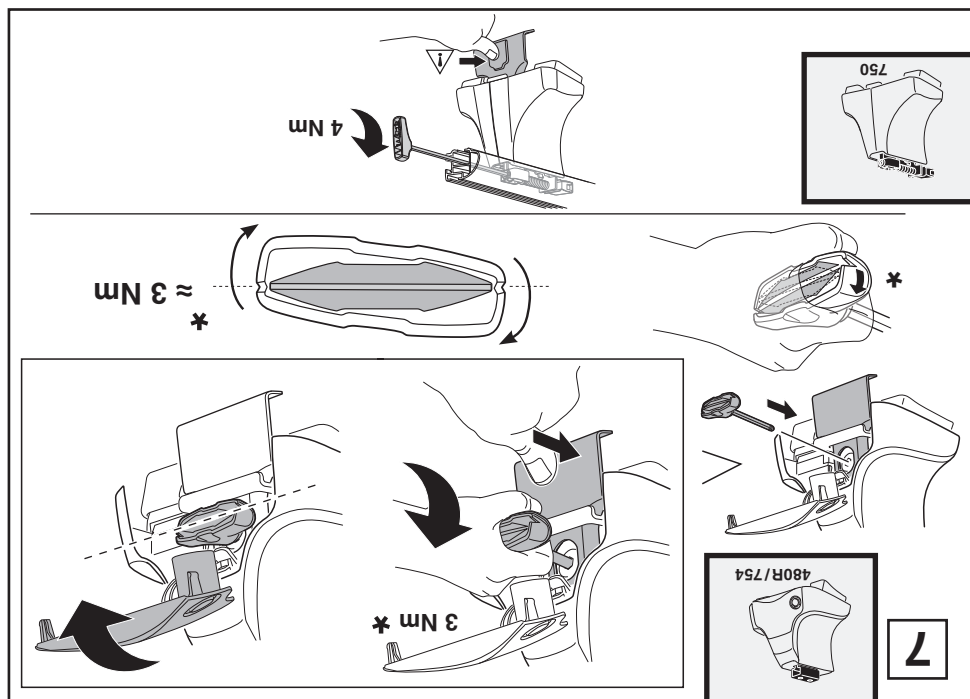
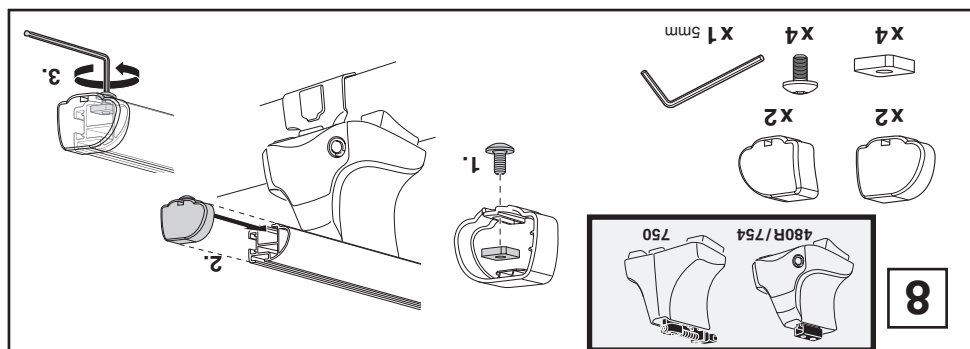
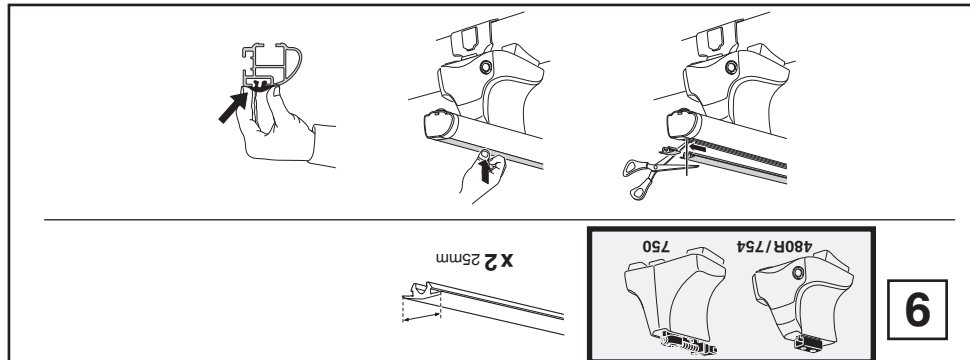

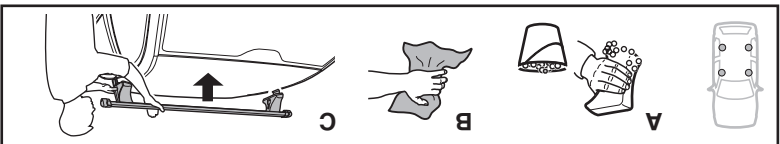

MITSUBISHI Pažero Sport, 5-dr SUV, 96-05	440mm	700 mm	17 3/8"	27 1/2"
MITSUBISHI Challenger, 5-dr SUV, 96-05	440 mm	700 mm	17 3/8"	27 1/2"
MITSUBISHI L200 (Mk 1), 4-dr Double Cab, 95-05	280 mm	750 mm	11"	29 1/2"
	X mm	Y mm	X inch	Y inch

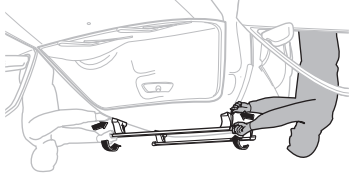
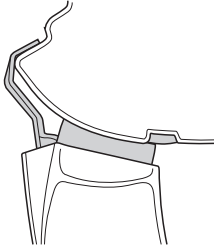
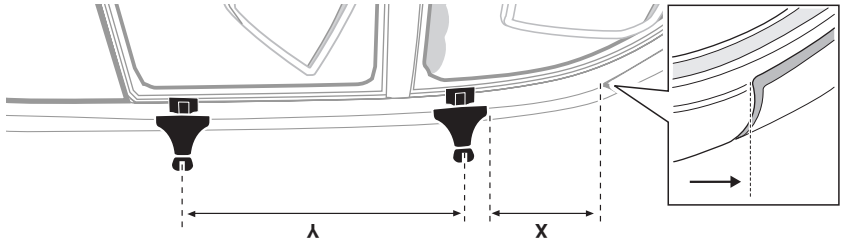

- FIN Kierä vuorotellen
- EST Pinguidage vaheldumisi
- LAT Pielveiciet pamīšus
- LIT Užsukinėkite pakatomis
- PL Słubę dokręcaj naprzemiennie
- RU Затягивайте попеременно
- CZ Pokrtejte bagazníka dokręcaj dokręcaj naprzemiennie.
- SK Dotiahnite striedavo
- SLO Privijajte izmenično.
- HR Naizmjenično zategnite
- HU Egyarástól fűggetlenül
- GR Zfilyyete evadäfts szortíandó
- TR Dönüşümlü sıkın
- 中文 交替拧紧
- 한국어 번갈아가며 조이십시오.
- 日本語 交互に締め付けてください。
- Им

- GB/US Tighten alternately
- D Die Schrauben abwechselnd anziehen
- F Serrer alternativement chaque côté
- NL Afwisselend aan de linker- en rechterkant aandraaien
- I Alternare il serraggio delle viti
- E Apretar alternativamente
- PT Apreta alternadamente
- S Dra åt växelvis

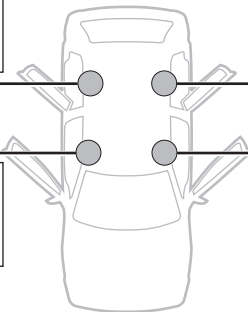
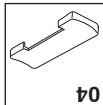
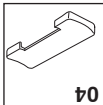
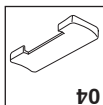
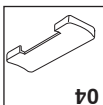
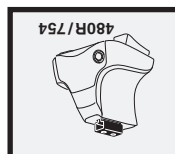
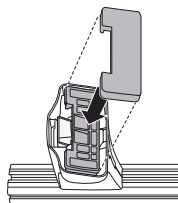
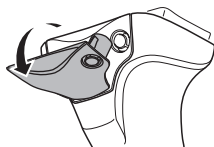
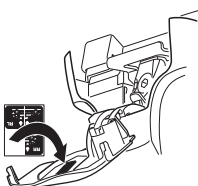
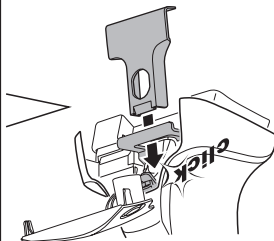
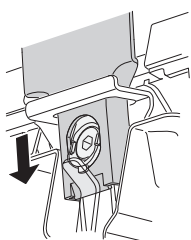
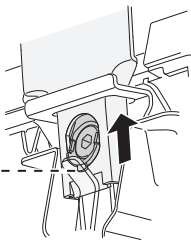
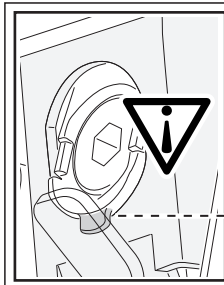
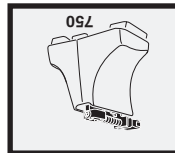
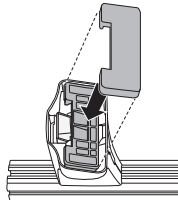
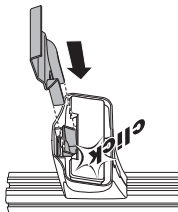
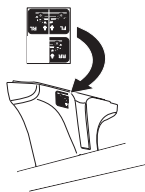

MITSUBISHI Pajero Sport, 5-dr SUV, 96-05
MITSUBISHI Challenger, 5-dr SUV, 96-05
MITSUBISHI L200 (Mk 1), 4-dr Double Cab, 95-05

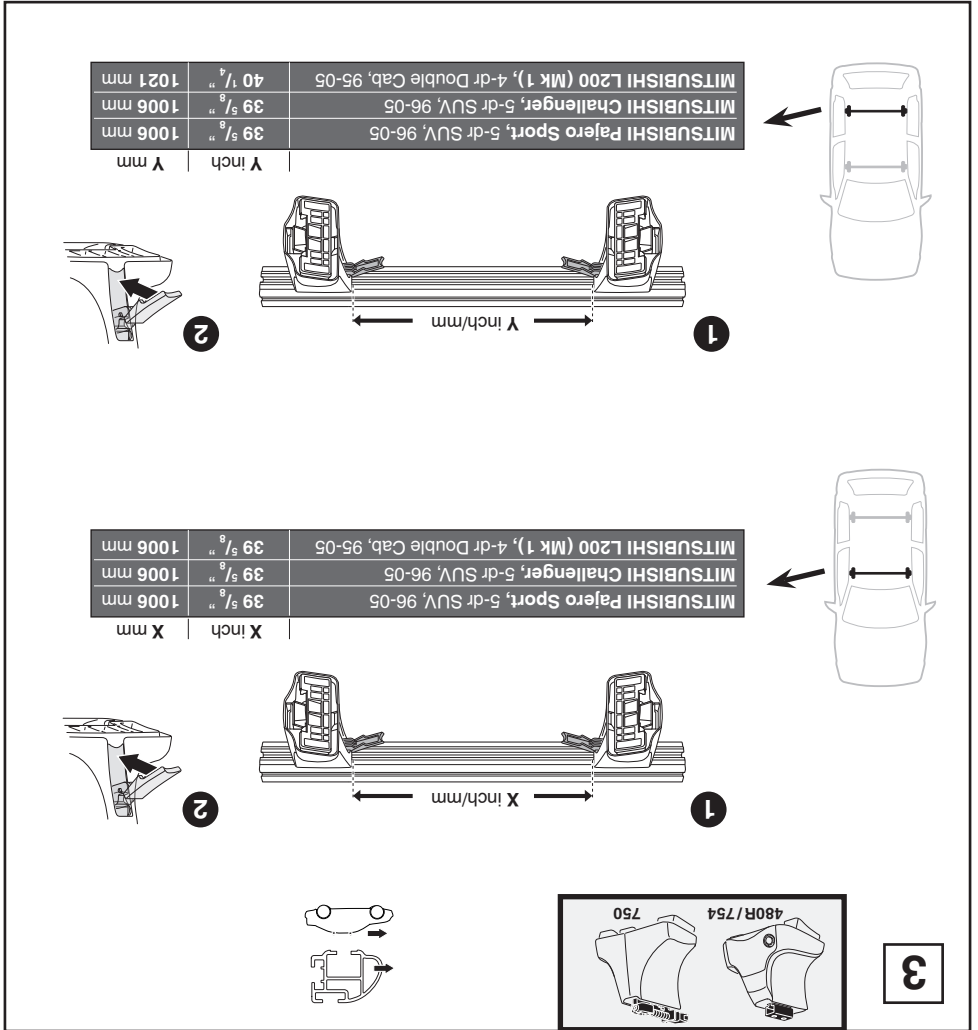
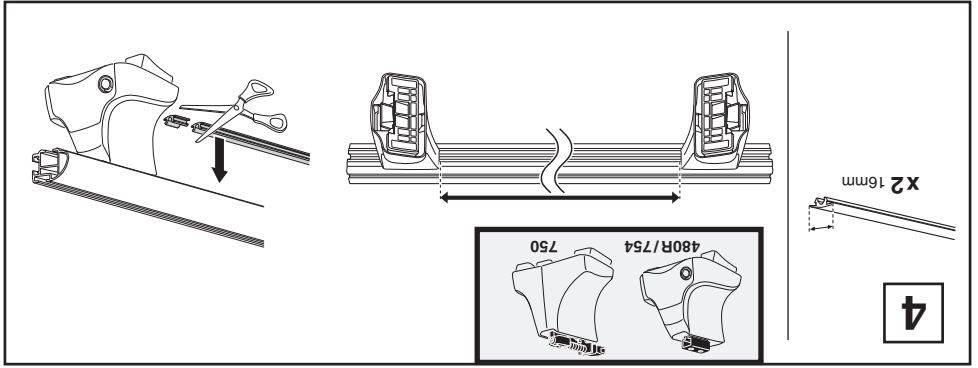

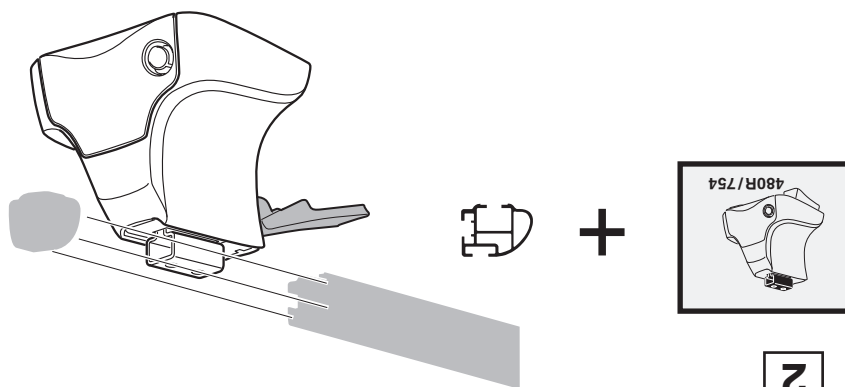
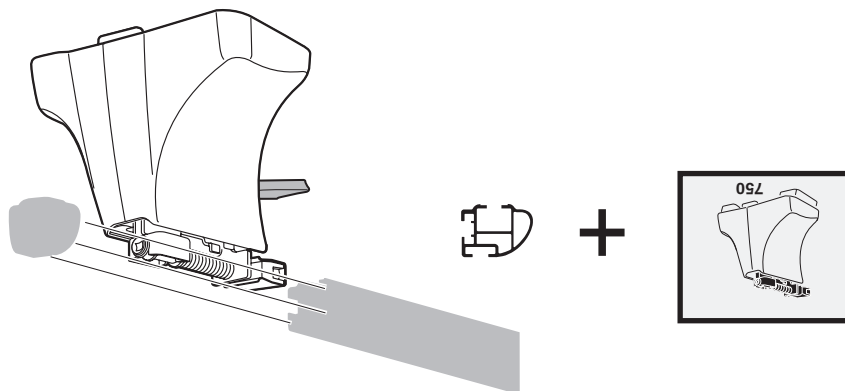

2

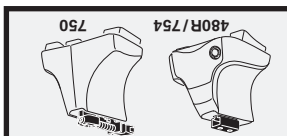
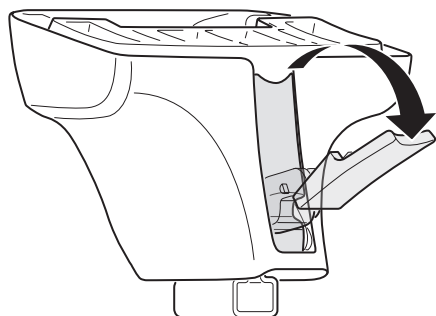

1

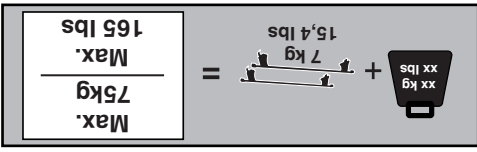
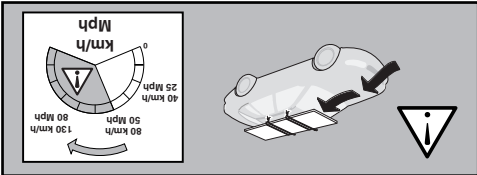
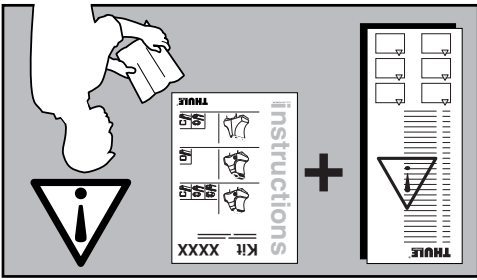
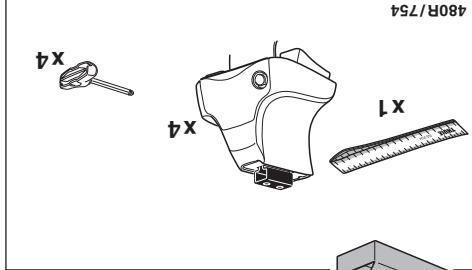
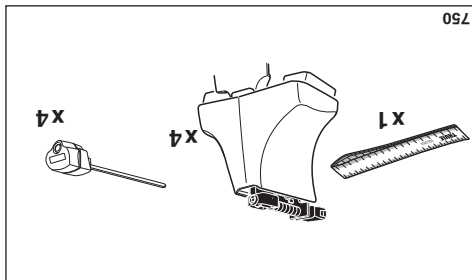
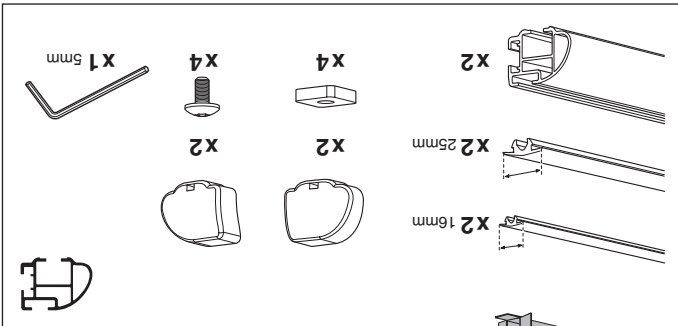
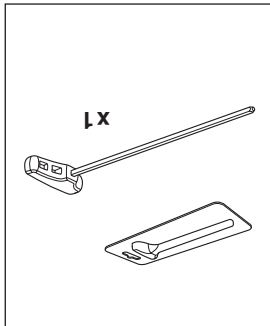
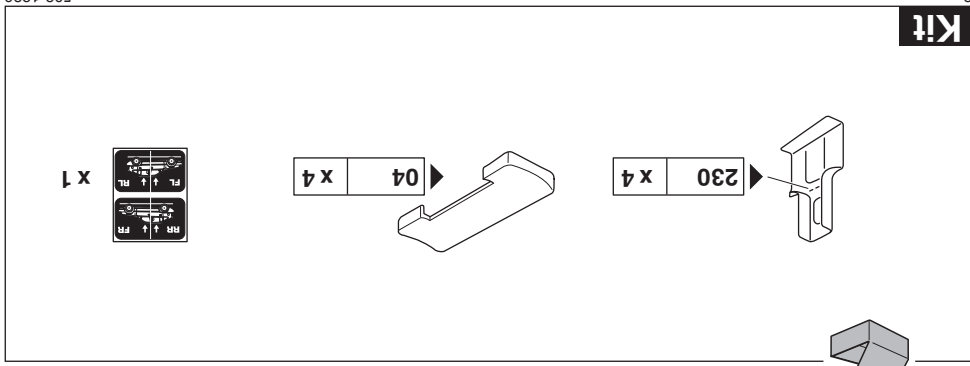

instructions

20090690 503-1236

ISO 11154-E

PROFESSIONAL

THULE
SWEDEN®

750

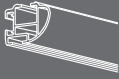
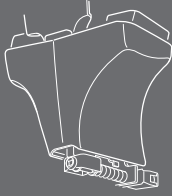

480R
754

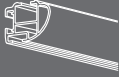
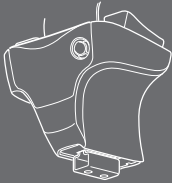

MITSUBISHI Pajero Sport, 5-dr SUV, 96-05
MITSUBISHI Challenger, 5-dr SUV, 96-05
MITSUBISHI L200 (Mk 1), 4-dr Double Cab, 95-05

Kit 1236