

THULE
SWEDEN

- GB** Fitting instructions
D Montageanleitung
F Instructions de montage
NL Montage-instructies
I Istruzioni per il montaggio
E Instrucciones de montaje
PT Instruções de Montagem
S Monteringsanvisning
FIN Asennusohje
EST Paigaldusjuhend
LAT Stiprināšanas instrukcija
LIT Pritvirtinimo instrukcijos
PL Instrukcja montażu
RU Инструкции по установке
CZ Návod na montáž
SK Návod na montáž
SLO Navodila za pritrjevanje
HR Uputa za sastavljanje
HU A felszerelés módja
GR Οδηγίες συναρμολόγησης
TR Montaj talimatları
中文 安装说明
日本語 取扱(取付)説明書
한국어 장착 지침
ไทย คำแนะนำการติดตั้ง

MITSUBISHI Lancer, 4-dr Sedan, 08-
MITSUBISHI Lancer, 5-dr Hatchback, 08-
MITSUBISHI Lancer EVO X, 4-dr Sedan, 08-

**RAPID
FIXPOINT XT**

3071
133071



Follow me...

912•A/501-3071-03

@ info@thule.com

www.thule.com
www.thuleprofessional.com

Thule Sweden AB, Box 69, 330 33 Hillerstorp, SWEDEN

1



x 4



x 4

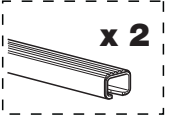

x 2

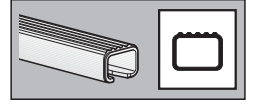
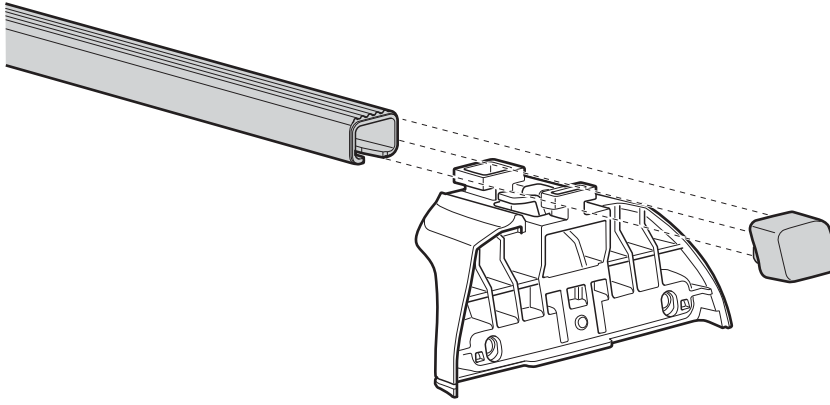

x 4

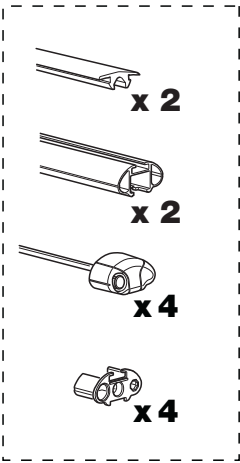

x 2

x 2

x 4

x 4

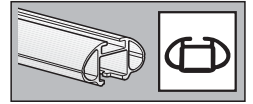
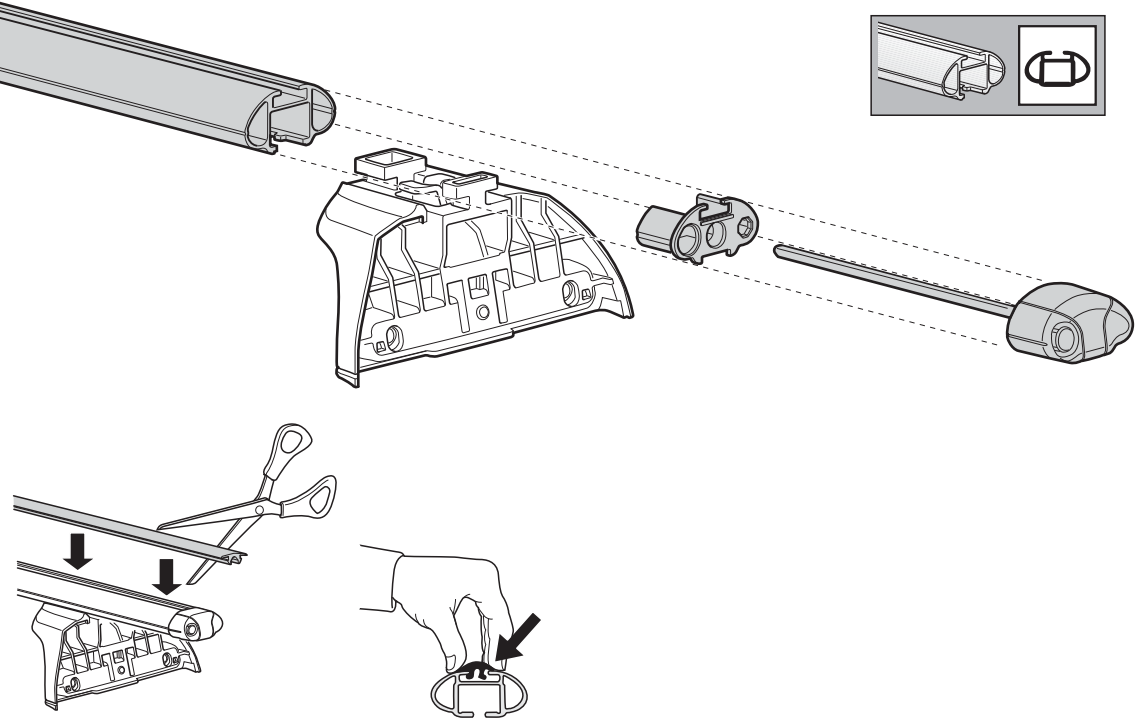

x 4

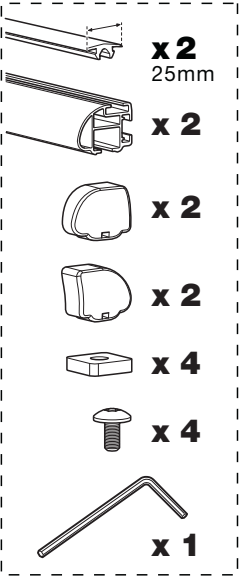

x 2

25mm

x 2

x 2

x 2

x 4

x 4

x 1

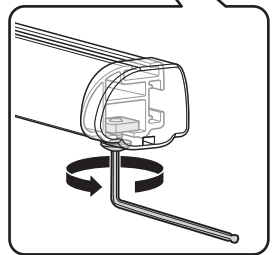
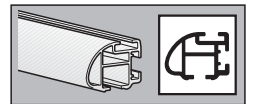
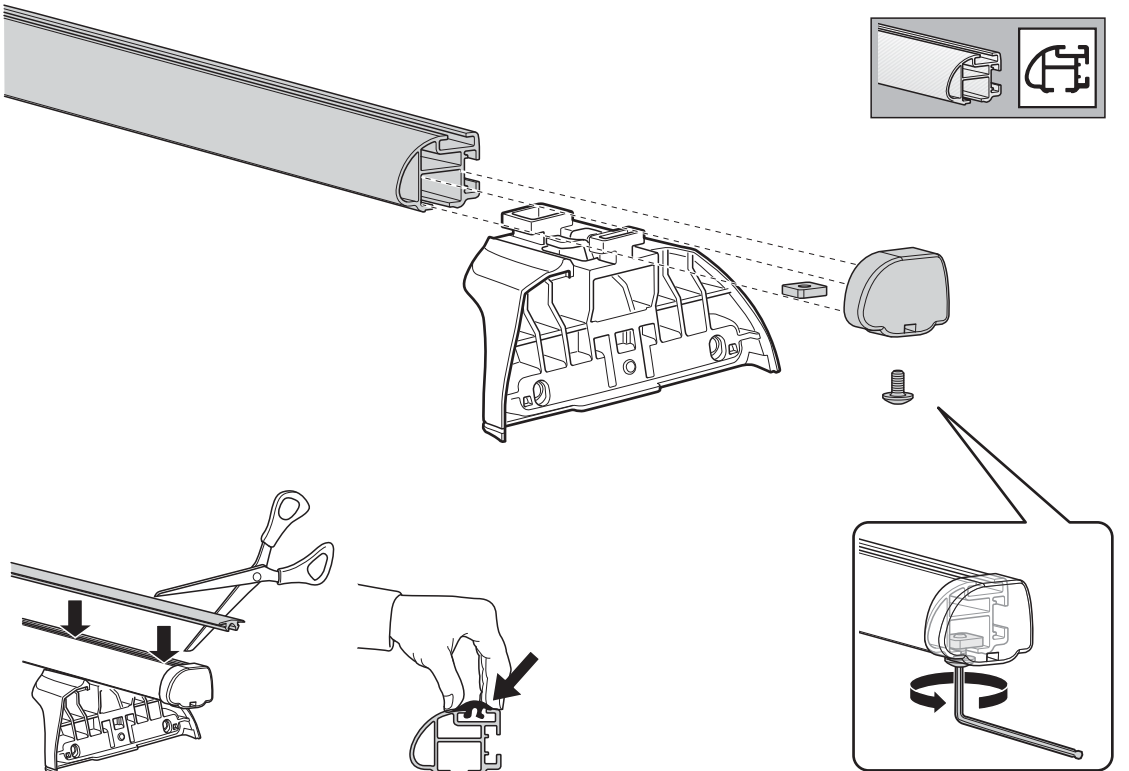

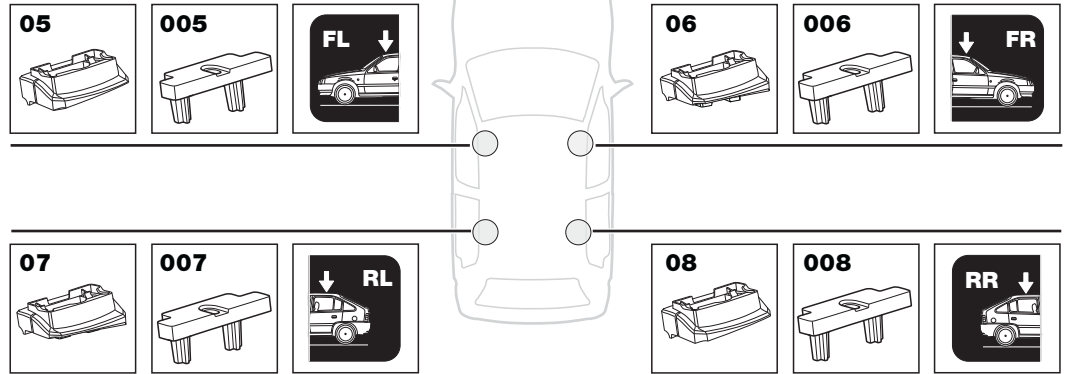
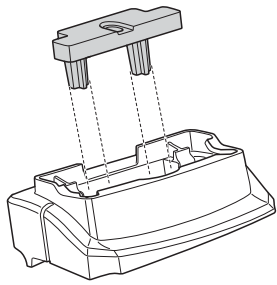
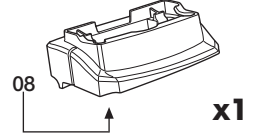
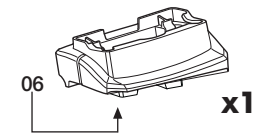
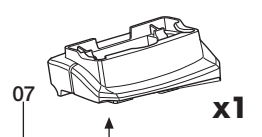
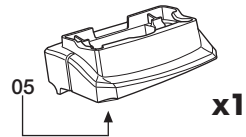
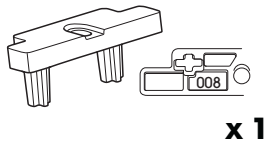
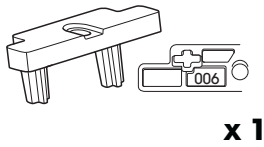
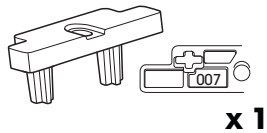
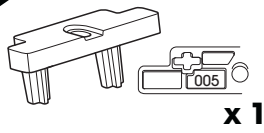
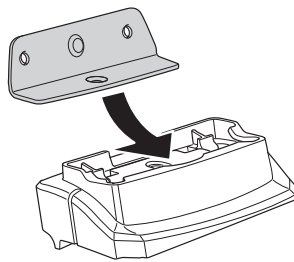
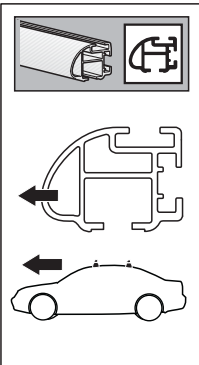
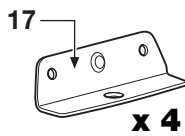
2**3**

- | | | | |
|------------|---------------------------|------------|--------------------------------|
| GB | Only a few turns | RU | Достаточно нескольких оборотов |
| D | Nur wenige Umdrehungen | CZ | Pouze několik otáček |
| F | Quelques tours uniquement | SK | Len niekoľko otáčok |
| NL | Slechts enkele slagen | SLO | Le nekaj obratov |
| I | Solo qualche giro | HR | Samo nekoliko okreta |
| E | Sólo algunas vueltas | HU | Csak néhány fordítás |
| PT | Noções básicas | GR | Μόνο μερικές στροφές |
| S | Endast några varv | TR | Yalnız birkaç kez çevirme |
| FIN | Vain muutama kierros | 中文 | 只有几个转向 |
| EST | Ainult mõni pööre | 한국어 | 두 세번만 |
| LAT | Tikai dažī apgriezieni | 日本語 | 数回転のみ |
| LIT | Tik keli pasukimai | ไทย | หมุนเพียงไม่กี่รอบ |
| PL | Wystarczy kilka obrotów | | |

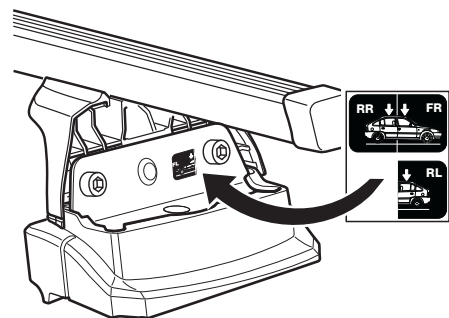
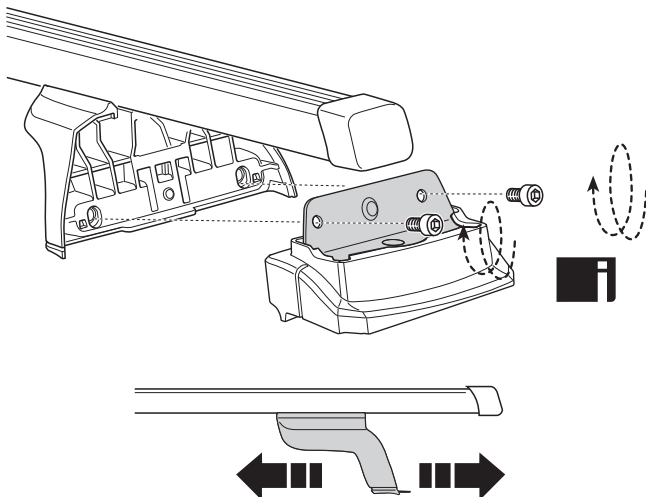

4

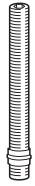

x 4



x 1 3mm

A

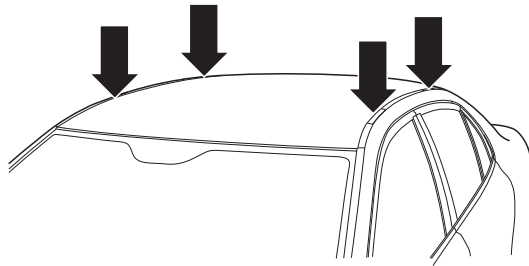

B

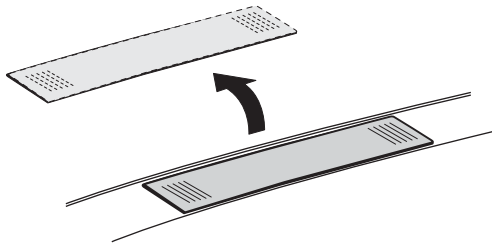

C

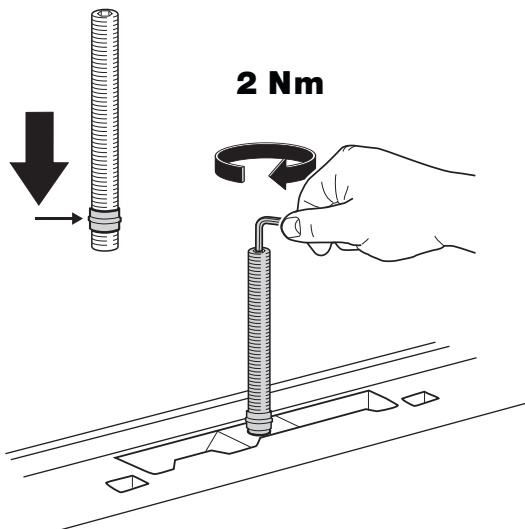

5



x 4



x 4

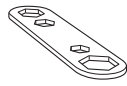

x 1

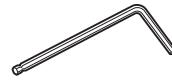

x 1 5mm

A

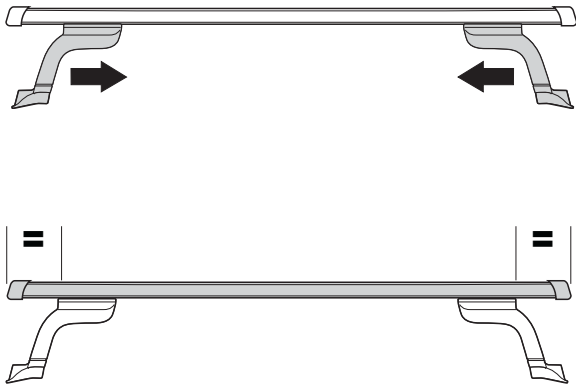

C

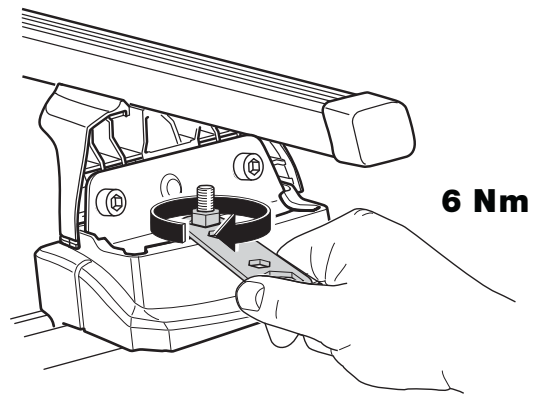

B

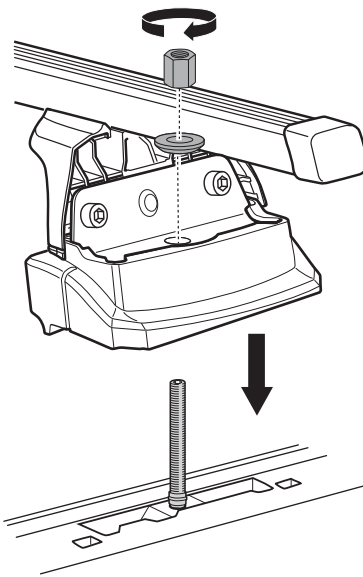

D

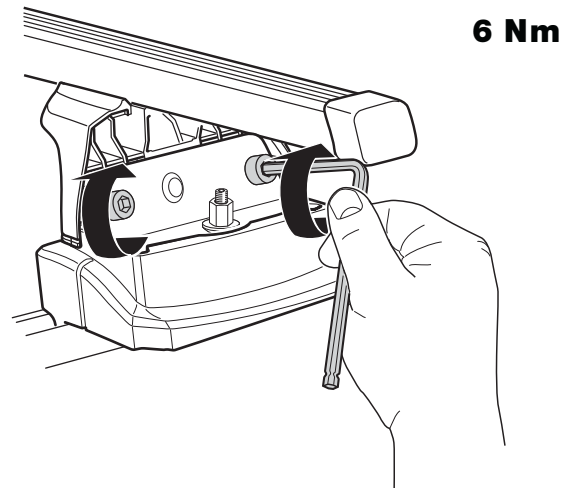

6



x 4



x 4



x 1

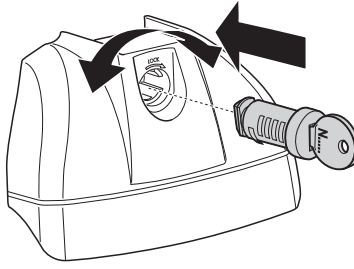

7

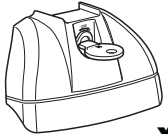

x 4

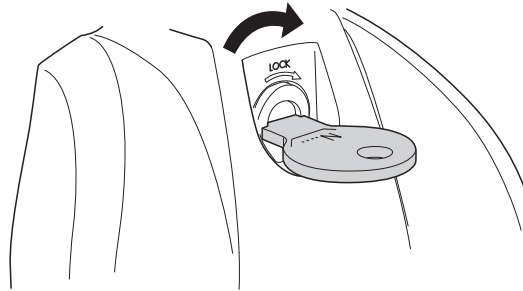
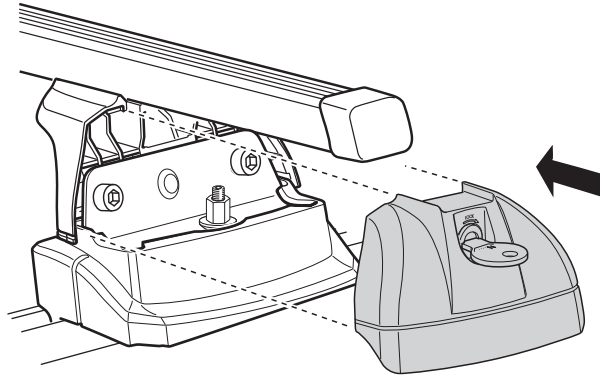

8

