

**THULE**<sup>®</sup>  
SWEDEN

- GB** Fitting instructions  
**D** Montageanleitung  
**F** Instructions de montage  
**NL** Montage-instructies  
**I** Istruzioni per il montaggio  
**E** Instrucciones de montaje  
**PT** Instruções de Montagem  
**S** Monteringsanvisning  
**FIN** Asennusohje  
**EST** Paigaldusjuhend  
**LAT** Stiprināšanas instrukcija  
**LIT** Pritvirtinimo instrukcijos  
**PL** Instrukcja montażu  
**RU** Инструкции по установке  
**CZ** Návod na montáž  
**SK** Návod na montáž  
**SLO** Navodila za pritrjevanje  
**HR** Uputa za sastavljanje  
**HU** A felszerelés módja  
**GR** Οδηγίες συναρμολόγησης  
**TR** Montaj talimatları  
中文 安装说明  
日本語 取扱(取付)説明書  
한국어 장착 지침  
ไทย คำแนะนำการติดตั้ง

*DAIHATSU Mira, 3/5-dr Hatchback, 99-02*  
*DAIHATSU Cuore, 3/5-dr Hatchback, 99-02*  
*PERUDOA Kelisa, 5-dr Hatchback, 01-*

**RAPID SYSTEM**

**Kit 1162**



**Follow me...**

**THULE**<sup>®</sup>  
SWEDEN

Box 69, 330 33 Hillerstorp, SWEDEN  
www.thule.com

819•4DF/8/501-1162-03

**THULE**

**GB** Security regulations  
**D** Sicherheits-Vorschriften  
**F** Instructions importantes  
**NL** Veiligheidsvoorschriften  
**I** Norme di sicurezza  
**E** Reglas de seguridad  
**PT** Normas de segurança  
**S** Säkerhetsföreskrifter  
**FIN** Turvallisuusohjeet  
**EST** Ohutusjuhised  
**LAT** Drošības noteikumi  
**LIT** Saugos taisyklės  
**PL** Wykazanie bezpieczeństwa  
**RU** Инструкции по безопасности  
**CZ** Pokyny na montáž  
**SK** Bezpečnostné predpisy  
**SLO** Varnostni predpisi  
**HR** Pravila sigurnosti  
**HU** Biztonsági előírások  
**GR** Κανονισμοί Ασφαλείας  
**TR** Güvenlik kuralları  
**CH** 安全規定  
**JP** 安全規定  
**TH** ปลอดภัยในการใช้งานผลิตภัณฑ์

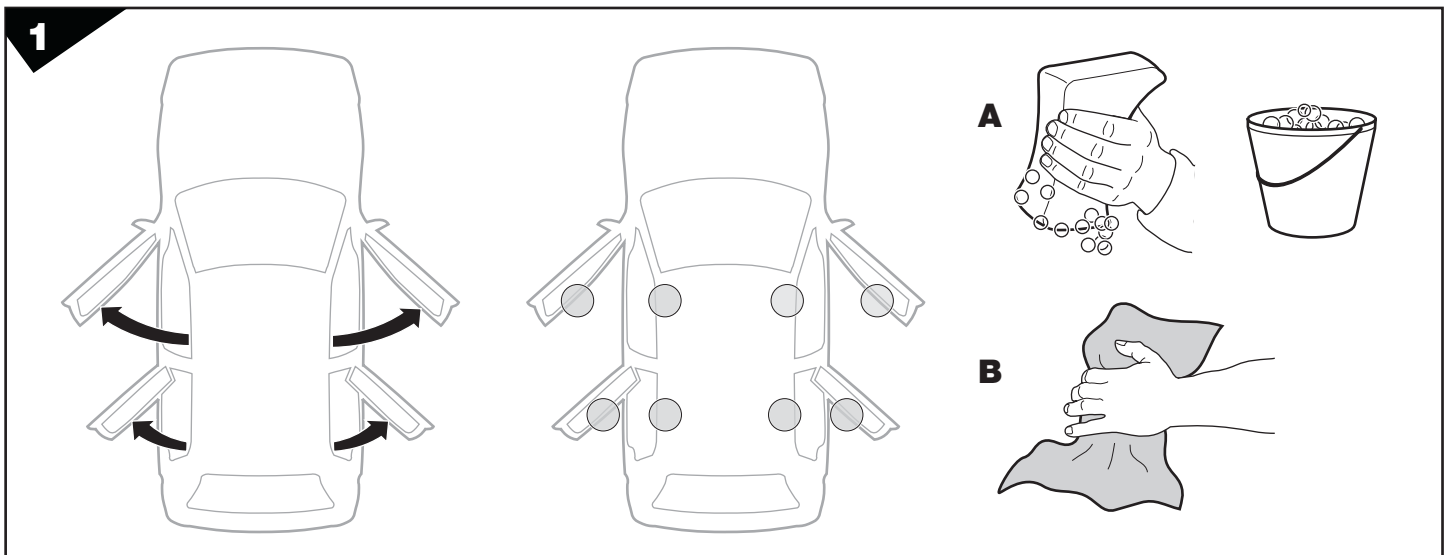
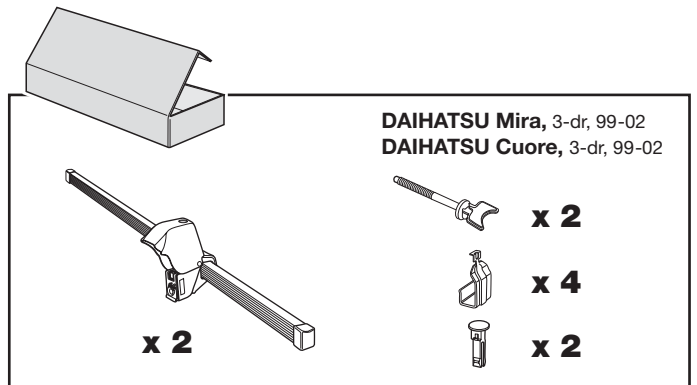
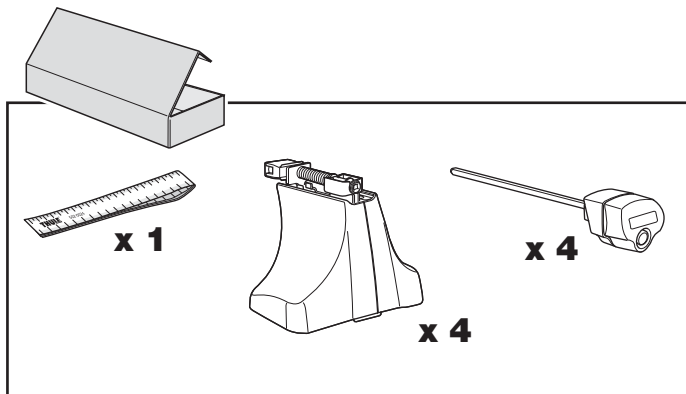
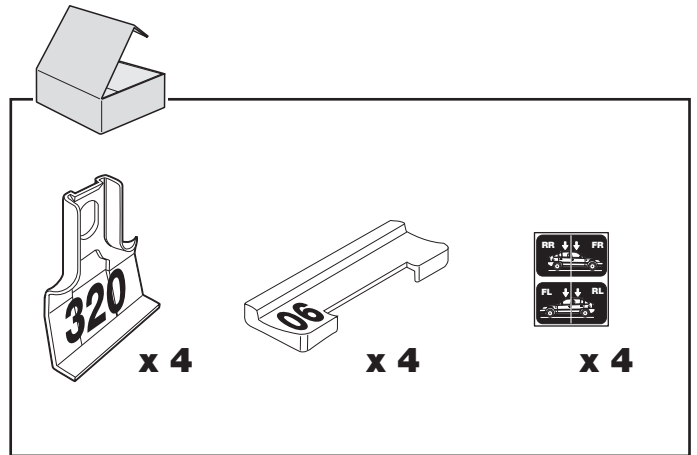
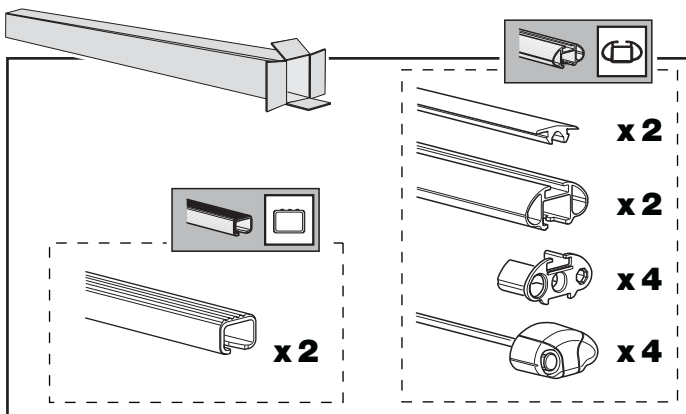
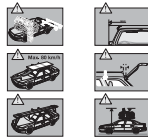
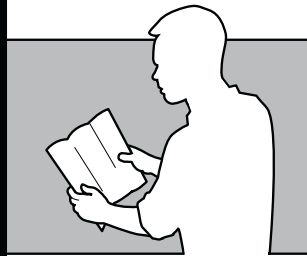

2

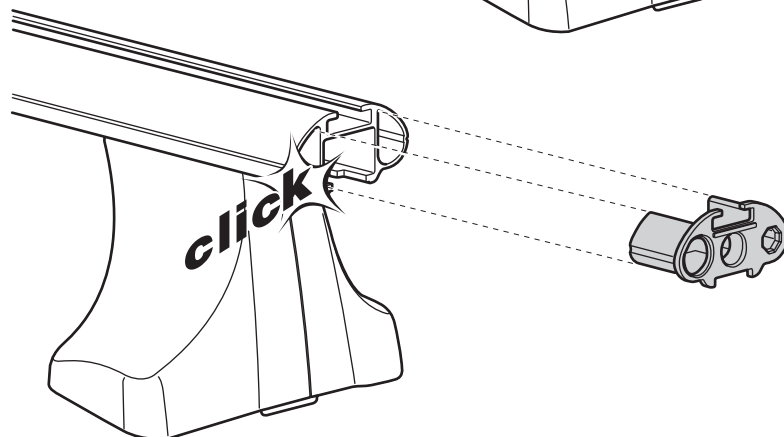
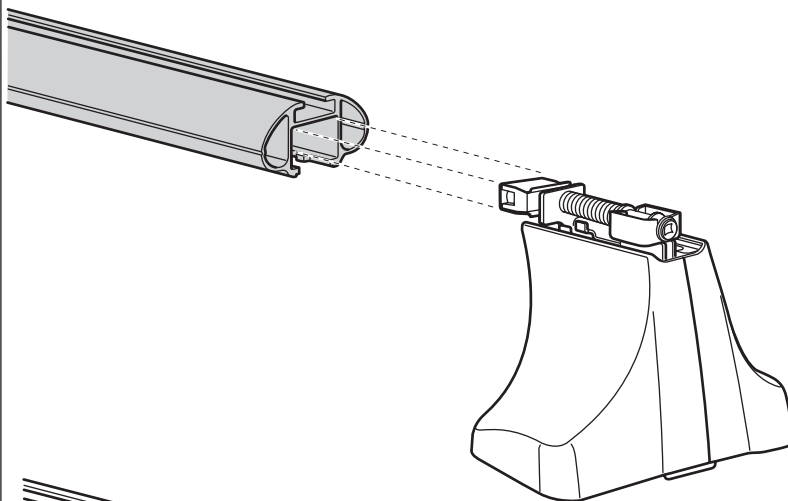
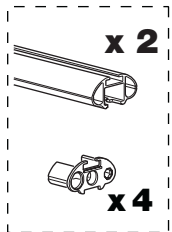
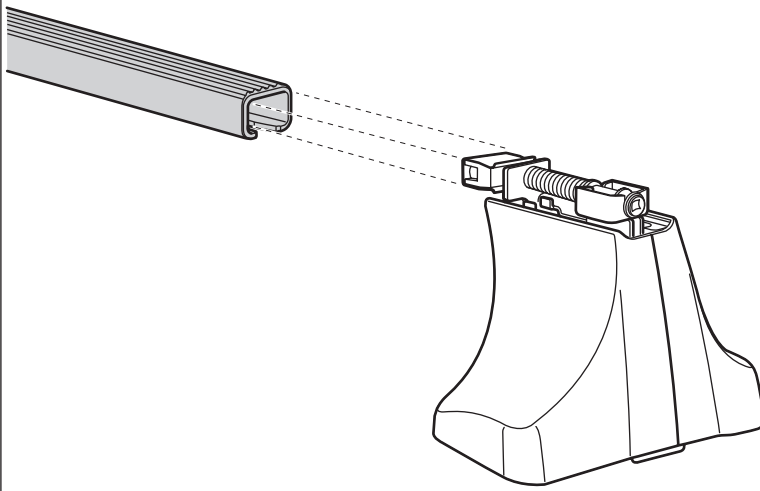
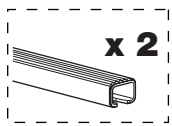
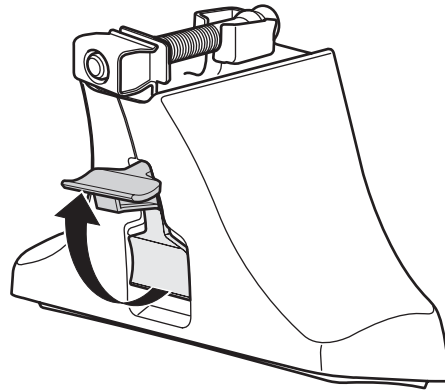
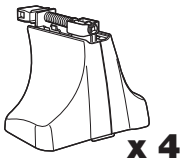

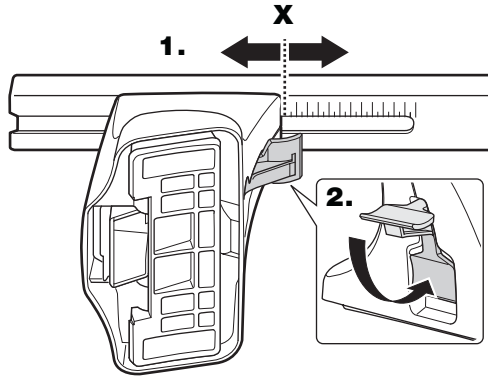
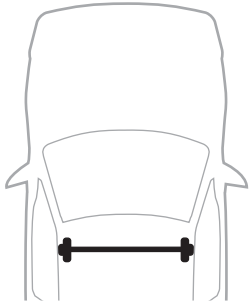
**3**

	<b>X</b>
DAIHATSU Mira, 3/5-dr Hatchback, 99-02	25,5
DAIHATSU Cuore, 3/5-dr Hatchback, 99-02	25,5
PERUDOA Kelisa, 5-dr Hatchback, 01-	25,5

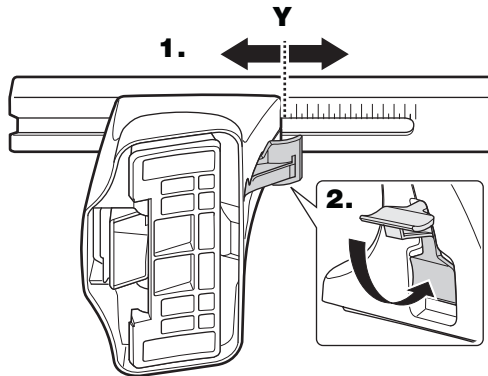
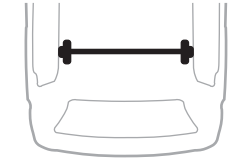

	<b>Y</b>
DAIHATSU Mira, 3/5-dr Hatchback, 99-02	25
DAIHATSU Cuore, 3/5-dr Hatchback, 99-02	25
PERUDOA Kelisa, 5-dr Hatchback, 01-	25

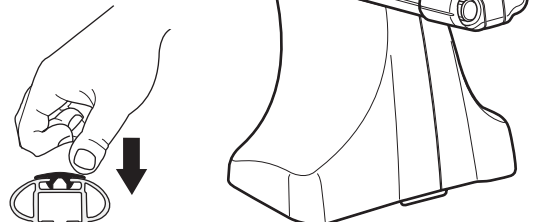
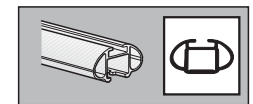
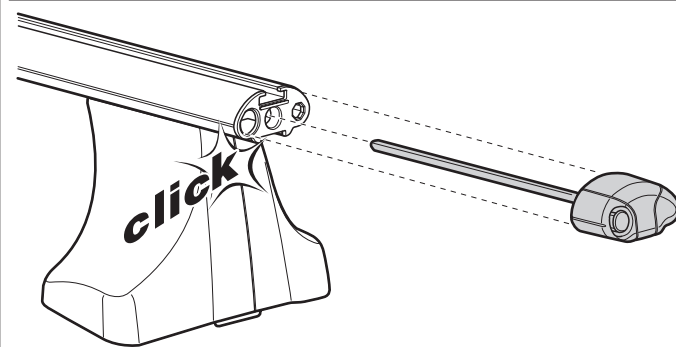
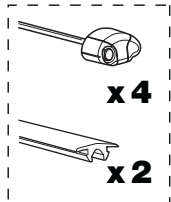
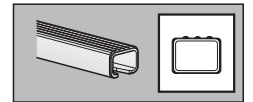
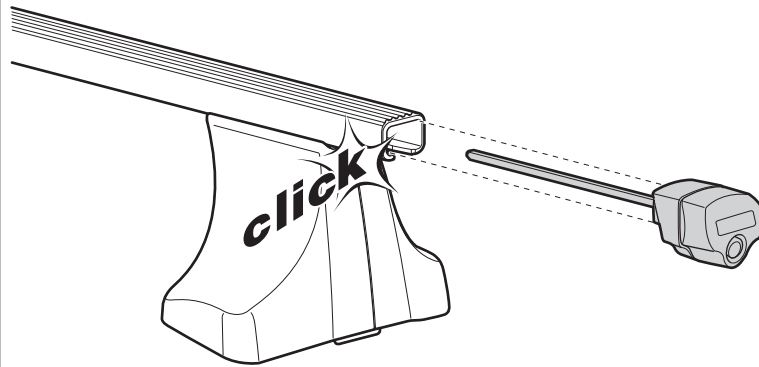
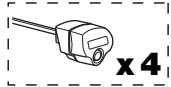
**4**

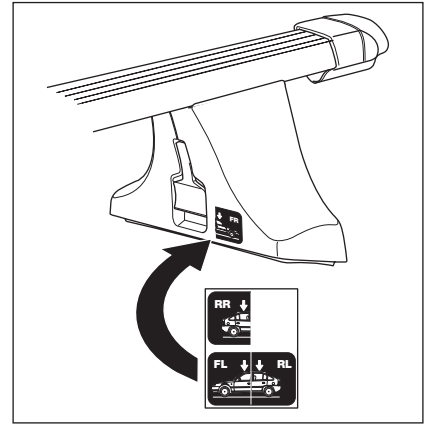
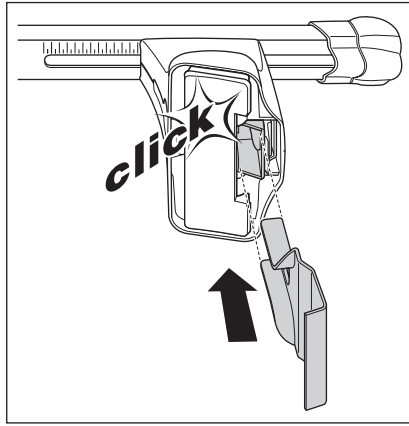
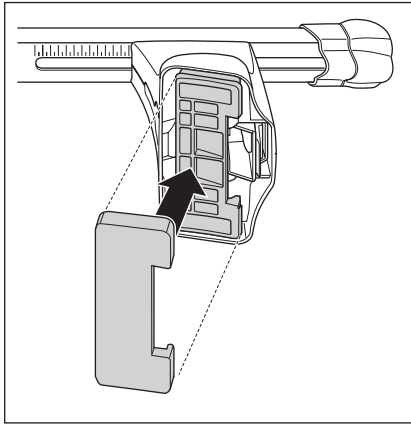

**DAIHATSU Mira**, 3-dr Hatchback, 99-02  
**DAIHATSU Cuore**, 3-dr Hatchback, 99-02

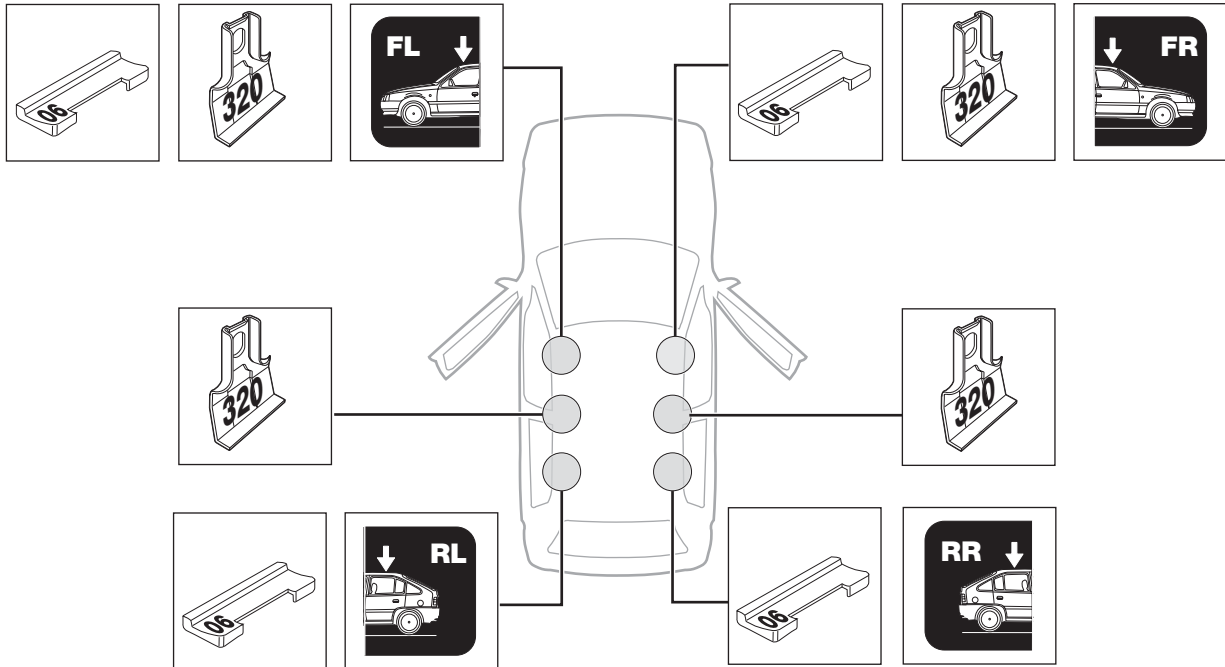
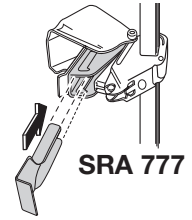
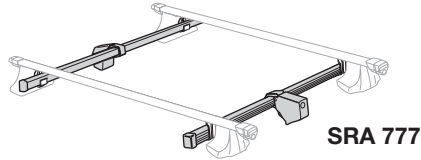

**DAIHATSU Mira**, 5-dr Hatchback, 99-02  
**DAIHATSU Cuore**, 5-dr Hatchback, 99-02  
**PERUDO A Kelisa**, 5-dr Hatchback, 01-

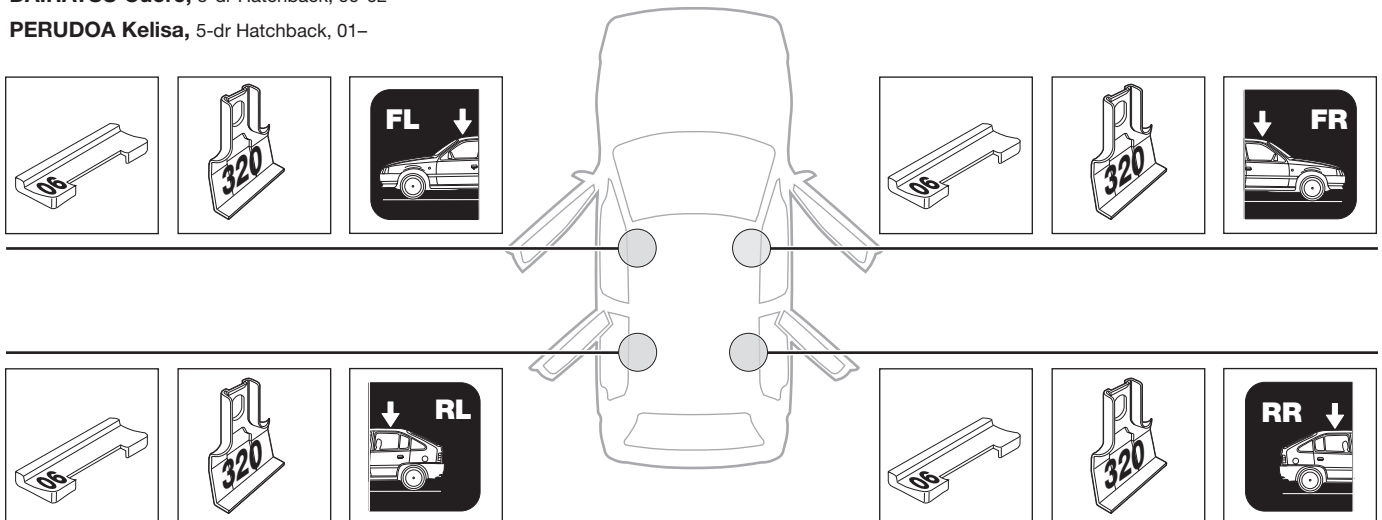

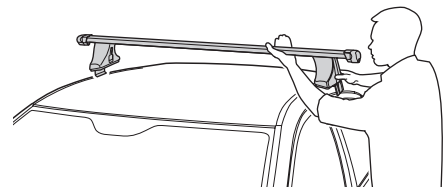
**6**

**DAIHATSU Mira**, 3-dr Hatchback, 99-02  
**DAIHATSU Cuore**, 3-dr Hatchback, 99-02

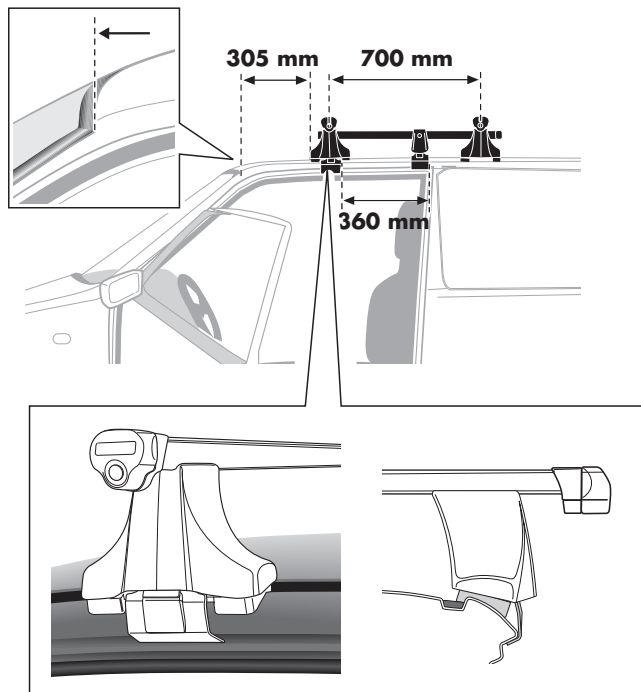

**DAIHATSU Mira**, 5-dr Hatchback, 99-02  
**DAIHATSU Cuore**, 5-dr Hatchback, 99-02  
**PERUDOA Kelisa**, 5-dr Hatchback, 01-

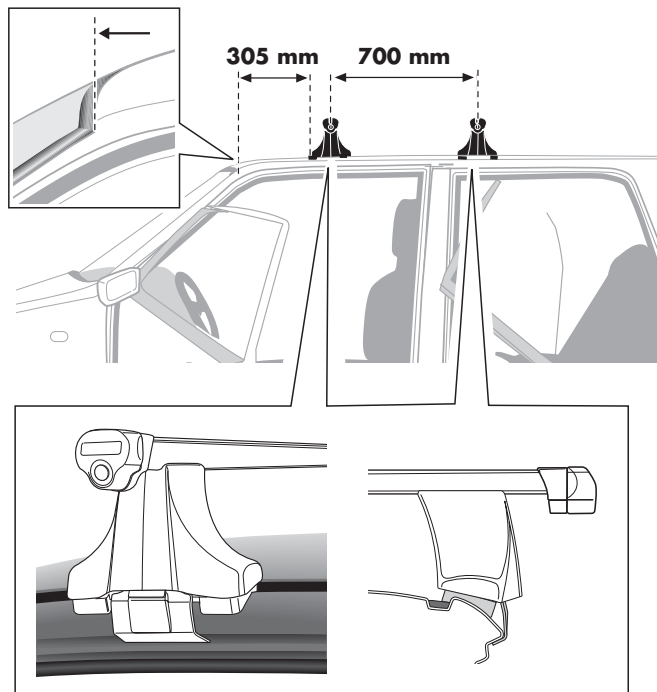
**7**

**GB** Tighten alternately  
**D** Die Schrauben abwechselnd anziehen  
**F** Serrer alternativement chaque côté  
**NL** Afwisselend aan de linker- en de rechterkant aandraaien  
**I** Serrare alternativamente  
**E** Alternare il serraggio delle viti  
**PT** Aperte alternadamente  
**S** Dra åt växelvis  
**FIN** Kierrä vuorotellen  
**EST** Pinguldage vaheldumisi  
**LAT** Pievelciēt pamišus  
**LIT** Užsukinėkite pakaitomis

**PL** Śruby dokręcaj naprzemiennie  
**RU** Затягивайте попеременно  
**CZ** Pokręťta багаžnika dokręcaj dokręcaj naprzemiennie.  
**SK** Doťahujte striedavo  
**SLO** Privijajte izmenično.  
**HR** Naizmjenično zategnite  
**HU** Egymástól függetlenül szorítandó  
**GR** Σφίγγετε εναλλάξ  
**TR** Dönüşümlü sıkın  
**中文** 交替拧紧  
**한국어** 번갈아 가며 조이십시오.  
**日本語** 交互に締め付けてください。  
**ไทย** ขันในแบบสลับ

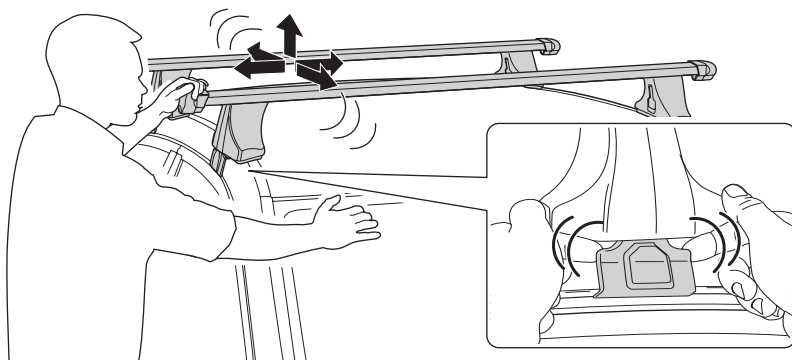
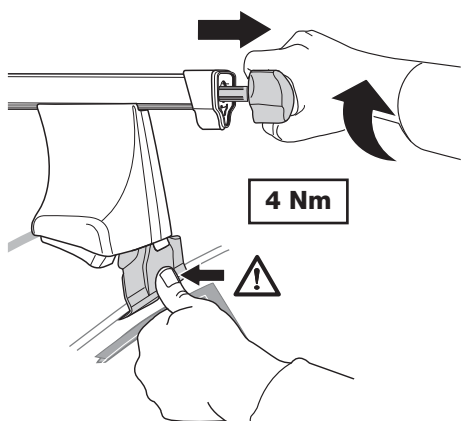
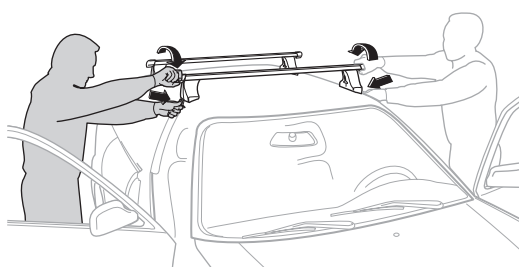

**GB** Removal  
**D** Demontieren  
**F** Démontage  
**NL** Demontage  
**I** Rimozione

**E** Desmontaje  
**PT** Remoção  
**S** Demontering  
**FIN** Irrotus  
**EST** Eemaldamine

**LAT** Noņemšana  
**LIT** Nuėmimas  
**PL** Wymontowywanie  
**RU** СНЯТИЕ  
**CZ** Odmontování

**SK** Demontáž  
**SLO** Odstranjevanje  
**HR** Uklanjanje  
**HU** Leszerelés  
**GR** Αφαίρεση

**TR** Sökme  
 中文 拆除  
 日本語 取り外し  
 한국어 분리  
 ไทย การถอด

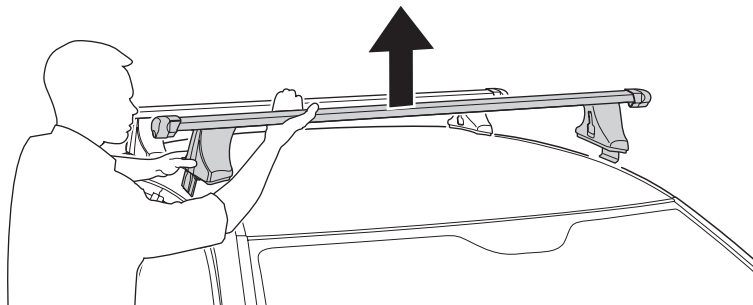
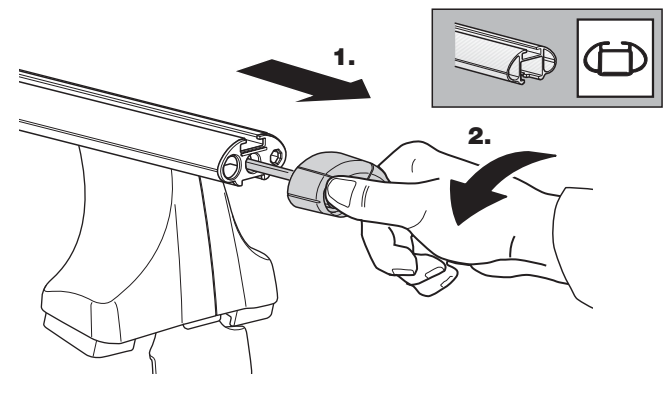
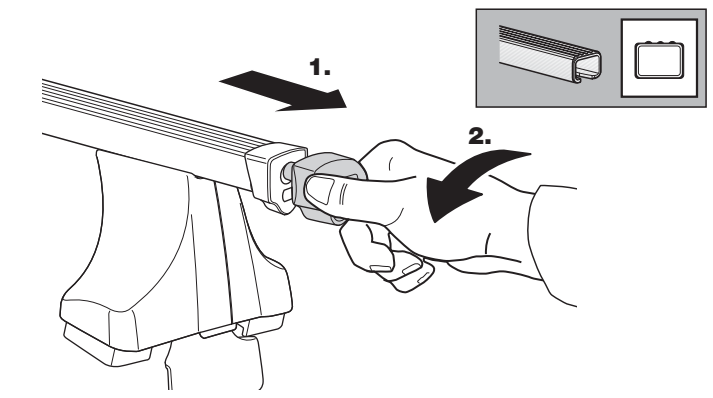

**Fit Tips!**

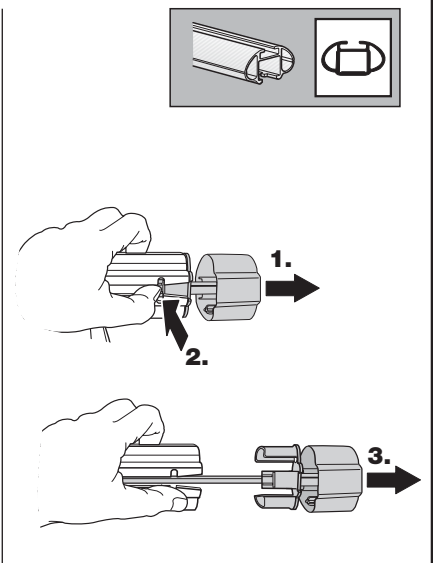
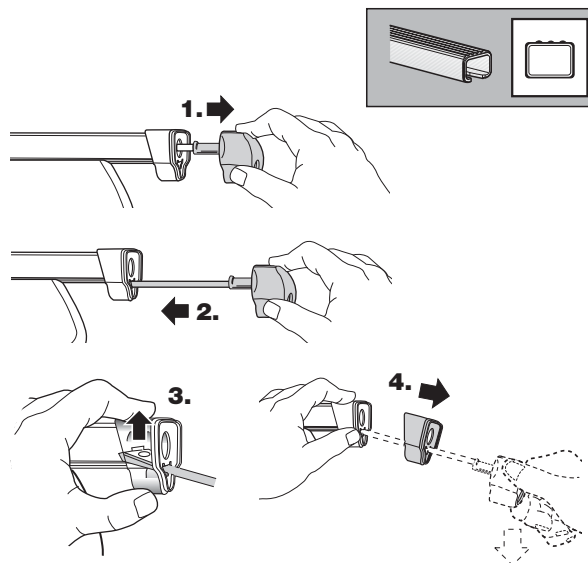
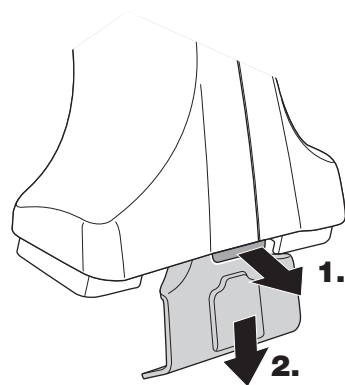

**THULE**  
**ONE**  
**KEY**  
**SYSTEM**

